



## **COMMITTEE DRAFT CARICOM REGIONAL STANDARD**

### **CONSTRUCTION OF HOUSES – CODE OF PRACTISE CD-CRCP xx: 202X**

CARICOM Regional Organisation for Standards and Quality (CROSQ)  
2<sup>nd</sup> Floor, Baobab Tower  
Warrens, St Michael  
Barbados  
Telephone: 246-622-7677  
Fax: 246-622-6778  
Email: [crosq.caricom@crosq.org](mailto:crosq.caricom@crosq.org)  
Website: <http://www.crosq.org>

© CROSQ 202X – All rights reserved. No part of this publication is to be reproduced without the prior written consent of CROSQ

ISBN XXXX-XXXX-XXX  
ICS xx.xxxx

**AMENDMENTS ISSUED SINCE PUBLICATION**

AMENDMENT NO.	DATE OF ISSUE	TYPE OF AMENDMENT	NO. OF TEXT AFFECTED	TEXT OF AMENDMENT

DCRCP 10 For Comments (Deadline 30-09-2022)

**ATTACHMENT PAGE FOR CRS AMENDMENT SHEETS**

DCRCP 10 For Comments (Deadline 30-09-2022)

## Committee representation

This CARICOM Regional Standard was developed under the supervision of the Regional Project Team (RPT) for Code of Practice for the Construction of Houses hosted by the CARICOM Member State, Dominica and St. Vincent and the Grenadines which at the time comprised the following members:

### Members

Dr. Bertilia Barley (Chairperson)

Mr. Aiden Greenaway

Mr. Nkosi Cochrane

Mr. Alexis Joseph

Mr. Corège Dorismond

Mr. Samuel Therassen

Mr. Colin Layne

Mr. Desmond Pompey

Mr. Imran Williams

Mrs. Cornelly Oliveira

Mr. Mario Wijntuin (Alternate)

Mr. Erick Redmount

Mr. Pierre Fitzgerald Van Zichem

Mr. Derrick Guiste

Dr. Gerona Joseph

Mr. Dwayne Roland

Ms. Heidi Gillette

Mr. Hemraj Sanichara

Mr. Dwight Simmonds (O)

Mr. Darryl Thomson

Ms. Lara Maharaj

Ms. Amreeka Maharaj (Alternate)

Mr. Lendel Bethelmy

Mr. Colin Sinarine (Alternate)

Mr. Humphrey Regis

Mr. Mark Renee

Mr. Rohan John Baptiste

Mrs. Jilian Portland (Alternate)

Ms Mara Abraham (Technical Secretary)

Ms Jennifer Douglas-Bullock (Technical Support)

### Representing

Ministry of Public Works and the Digital Economy, Dominica

Department of Environment, Antigua and Barbuda

Development Control Authority, Antigua and Barbuda

Bureau du Secrétaire d'État pour l'Intégration des Personnes Handicapées, Haiti

Ministère des Travaux Publics, Transports et Communication, Haiti

Institut National de la Formation Professionnelle, Haiti

Physical Planning Department, St. Vincent and the Grenadines

Physical Planning Department, St. Vincent and the Grenadines

Physical Planning Department, St. Vincent and the Grenadines

n.v. Cornelly's GALA-XY – TACO OSO (Building division), Suriname

N.V. Energybedrijven Suriname (N.V. EBS)., Suriname

General Contractors Association, Suriname

Chamber of Commerce & Industry, Suriname

Dominica State College, Dominica

Climate Resilience Executing Agency of Dominica (CREAD), Dominica

Ministry of Public Works, Guyana

Guyana Association of Professional Engineers, Guyana

Guyana Bureau of Standards, Guyana

St. Kitts and Nevis

Trinidad and Tobago Bureau of Standards, Trinidad and Tobago

National Training Agency, Trinidad and Tobago

National Training Agency, Trinidad and Tobago

Association of Professional Engineers of Trinidad and Tobago, Trinidad and Tobago

Association of Professional Engineers of Trinidad and Tobago, Trinidad and Tobago

Ministry of Physical Development, Housing and Urban Renewal Architectural Section, Saint Lucia

Renee's Construction Co. Ltd, Saint Lucia

Sir Arthur Lewis Community College, Saint Lucia

Saint Lucia Bureau of Standards, Saint Lucia

Dominica Bureau of Standards

St. Vincent & The Grenadines Bureau of Standards

## Contents

Foreword .....	1
1 Scope .....	3
2 Normative references .....	3
3 Terms and definitions .....	3
4 Symbols and abbreviated terms .....	3
5. Specifications .....	4
5.1 Construction materials .....	4
5.1.1 Cement .....	4
5.1.2 Sand (fine aggregate) .....	4
5.1.3 Stone (coarse aggregate) .....	4
5.1.4 Water .....	4
5.1.5 Concrete .....	4
5.1.6 Grout .....	4
5.1.7 Mortar .....	4
5.1.8 Mixing cementitious materials .....	5
5.1.9 Concrete curing agent .....	6
5.1.10 Formwork release agent .....	6
5.1.11 Reinforcement (rebar) .....	6
5.1.12 Rebar bend diameters .....	6
5.1.13 Rebar lap lengths .....	7
5.1.14 Anchor bolts in concrete .....	7
5.1.15 Reinforced concrete .....	7
5.1.16 Concrete cover .....	7
5.1.17 Concrete blinding .....	8
5.1.18 Concrete formwork .....	8
5.1.19 Concrete spacer blocks .....	8
5.1.20 Concrete and clay blocks .....	9
5.1.21 Concrete and clay block rebars .....	10
5.1.22 Fill .....	10
5.1.23 Utility pipes (plumbing, electrical, and communications) .....	10
5.1.24 Timber frames .....	10
5.1.25 Timber walls on concrete .....	10
5.1.26 Nails .....	11
5.1.27 Roof metal cladding .....	11
5.1.28 Damp proofing membrane (DMP) .....	11
5.2 Pre-construction planning .....	11
5.2.1 Planning Approval .....	11
5.2.2 Contract .....	11
5.2.3 Insurance .....	12
5.2.4 Drawing Review .....	12
5.3 Site preparation .....	12
5.3.1 Site Inspection .....	12
5.3.2 Site Investigation .....	12
5.3.3 Work plan .....	12
5.3.4 Setting Out .....	12
5.3.5 Material storage .....	12
5.3.6 Batter Boards .....	13
5.3.7 Risk Assessments .....	13
5.4 Foundations .....	13
5.4.1 Bearing capacity .....	13
5.4.2 Excavations .....	14
5.4.3 Termite treatment .....	14
5.4.4 Footings .....	14
5.5 Floors .....	19
5.5.1 Reinforced concrete slab on fill .....	19
5.5.2 Suspended reinforced concrete floor slab .....	19
5.5.3 Cantilevered reinforced concrete slab .....	20

5.5.4	Suspended Timber Floor.....	21
5.6	Walls and beams.....	24
5.6.1	Concrete block walls.....	24
5.6.5	Timber walls.....	27
5.7	Roof.....	28
5.7.4	Roof on masonry walls.....	30
5.7.5	Roof on timber framed walls.....	30
5.7.6	Reducing the Span.....	30
5.7.7	Roof Connections.....	31
Annex A	.....	33
A.1	Post-construction maintenance.....	33
A.2	Design for Elderly and Disabled People.....	33
A.2.1	Maintenance.....	33
A.2.2	Building Access.....	33
A.2.3	Doors and Corridors.....	34
A.2.4	Kitchen, Laundry and Bathrooms.....	34
A.2.5	Electrical Light Fixtures.....	34

DCRCP 10 For Comments (Deadline 30-09-2021)

## Foreword

This CARICOM Regional Standard CRS xx: 202X, Construction of Houses – Code of Practice has been developed under the authority of the CARICOM Regional Organisation for Standards and Quality (CROSQ). It was approved as a CARICOM Regional Standard by the CARICOM Council for Trade and Economic Development (COTED) at its xx<sup>th</sup> Meeting in MM YYYY.

Residents in CARICOM Member States risk being impacted by a diverse set of natural hazards including: earthquakes, hurricanes, floods, landslides, volcanoes, tsunamis, torrential rainfall, and the predicted negative effects of climate change. Houses built in CARICOM Member States may be prematurely weakened by: corrosion, moisture, insects, heat, and the sun's ultra-violet rays.

This standard is intended to outline the specifications for constructing houses in CARICOM Member States. It was necessary to develop this standard to align the residential construction industry in CARICOM Member States, to a common standard of strength and durability.

In formulating this standard considerable assistance was derived from the following:

### British Standards Institute (BSI)

- BS EN 1992-1-1:2004. Eurocode 2: Design of concrete structures. Part 1-1: General rules and rules for buildings. British Standards Institution. 2004.
- BS EN 206:2013+A1:2016. Concrete – Specification, performance, production and conformity. British Standards Institution. 2016.
- BS 4449:2005. Steel for the reinforcement of concrete – Weldable reinforcing steel – Bar, coil and decoiled product – Specification. British Standards Institution. 2005.
- BS 4482:1985. Cold reduced steel wire for the reinforcement of concrete. British Standards Institution. 1985.
- BS 8666:2005. Scheduling, dimensioning, bending and cutting of steel reinforcement for concrete – Specification. British Standards Institution. 2005.
- 

### American Society for Testing and Material (ASTM)

- ASTM C90-16. Standard Specification for Loadbearing Concrete Masonry Units. ASTM International. 2016.
- ASTM A615-15. Standard Specification for Deformed and Plain Carbon-Steel Bars for Concrete Reinforcement. ASTM International. 2015.
- ASTM C652-19 Standard Specification for Hollow Brick (Hollow Masonry Units Made From Clay or Shale). ASTM International. 2019.
- ASTM A653-15. Standard Specification for Steel Sheet, Zinc-Coated (Galvanized) or Zinc-Iron Alloy-Coated (Galvannealed) by the Hot-Dip Process. ASTM International. 2015
- ASTM A924-17. Standard Specification for General Requirements for Steel Sheet, Metallic-Coated by the Hot-Dip Process. ASTM International. 2017.

### American Concrete Institute

- ACI 318-14, Building Code Requirements for Structural Concrete, 2014.

American Society of Civil Engineers.

- ASCE 7-16, Minimum Design Loads and Associated Criteria for Buildings and Other Structures, 2017.
- ASCE 7-05, Minimum Design Loads and Associated Criteria for Buildings and Other Structures, 2006.

American Wood Council.

- National Design Specification for Wood Construction with Commentary, 2018.

The Masonry Society.

- TMS-402/602-16, Building Code Requirements and Specification for Masonry Structures, 2016.

Organisation of Eastern Caribbean States.

- OECS Building Code, 2016.

DCRCP 10 For Comments (Deadline 30-09-2022)



## 1 Scope

1.1. This document is applicable to the structural construction of houses in the Caribbean. It applies to single storey houses up to 7.62 m x 12.19 m (25 ft x 40 ft) plan, with masonry or timber framed walls, and timber framed or concrete roofs. It provides the user with the technical information to: (i) supervise the construction of a safe and durable house, and (ii) check whether a safe and durable house is being built.

1.2. This document does not include construction details for utilities (including plumbing, electrical, communications, security, and natural gas), since these are normally outsourced to specialist sub-contractors.

1.3. For houses of structural steel construction, guidance should be sought from the Trinidad and Tobago Standard (TTS 599:2006) Guide to the design and construction of small buildings.

1.4. Post construction maintenance is important, but it is not a mandatory part of this document. Therefore, it is included in Annex A. Designing for disabled persons is important, but it is not a mandatory part of this document. Therefore, it is included in Annex A.

## 2 Normative references

The following documents are referred to in the text in such a way, that some of their content constitutes requirements of this document. For dated references, only the edition cited applies. For undated references, the latest edition of the referenced document (including any amendments) applies.

**Organisation of Eastern Caribbean States.**  
OECS Building Code, 2016.

## 3 Terms and definitions

For the purposes of this document, the following terms and definitions apply.

### 3.1

#### **Curing**

Allowing concrete to attain its design compressive strength, by keeping it continuously moist, damp, or wet, and avoiding it from becoming dry, for a duration of seven (7) days.

### 3.2

#### **Slump**

A measure of the workability of concrete. It is measured by filling a 300 mm (12") high x 200 mm base x 100 mm frustum slump cone, in three equal compacted lifts of 100 mm (4").

The concrete is compacted using the 16 mm (5/8") dia. rod with end rounded as the tamping rod and tamping for 28 times for each lift; then lifting the cone, and measuring the slump, which is the distance between the height of the cone and the height of the concrete.

## 4. Symbols and abbreviated terms

ft	Foot or feet
g	Gravity
gal	US gallon
km	Kilometre
kN	Kilonewton
kg	Kilogram
m	Metre
m <sup>2</sup>	Square metre
m <sup>3</sup>	Cubic metre

mm	Millimetre
MPa	Megapascal
mph	Miles per hour
m/s	Meters per second
Mw	Moment magnitude
No.	Number
psi	Pounds per square inch
sq-ft	Square feet
SS	Structural Select
US	United States of America

## 5. Specifications

### 5.1 Construction materials

#### 5.1.1 Cement

For normal use above ground, and for footings bearing on limestone, cement should be Ordinary Portland Cement (Type I, CEM I, or equivalent). For footings in high sulphate soils, the cement should be Sulphate Resistant Cement (Type V or equivalent). For concrete or plaster in dense urban areas, with high automobile traffic, the cement may also be Sulphate Resistant (Type V or equivalent).

#### 5.1.2 Sand (fine aggregate)

Sand (fine aggregate) should be clean and natural from an inland source, free of clay, organic material, and broken shells. Beach sand should not be used. Where this is not available, sand may be derived from the crushing of larger aggregates.

#### 5.1.3 Stone (coarse aggregate)

Stone (coarse aggregate) should be crushed stone or gravel with a minimum size of 6 mm (1/4") and a maximum size of 20 mm (3/4"), free of a coating of dust.

#### 5.1.4 Water

Water should be clean and free of impurities such as salt, which may affect the concrete quality. A continuous supply of water should be available during all concrete mixing, placing and curing operations.

#### 5.1.5 Concrete

Concrete is a specific mixture of cement, sand, aggregate, and water, with a slump between 50 mm (2") and 100 mm (4"). Concrete in a mixer to be used within 1.25 hours (75 minutes) after adding water. Admixture agents may be added to achieve: (i) better flow with a higher slump (superplasticiser), (ii) delayed setting (retarder), or (iii) rapid setting. In this standard, concrete is used to construct concrete: footings, walls, beams, columns, and slabs.

#### 5.1.6 Grout

Grout is a specific mixture of cement, sand, aggregate, and water with a slump of between 115 mm (4.5") and 230 mm (9"). In this standard, grout is used to fill cores in concrete masonry blocks.

#### 5.1.7 Mortar

Mortar is a specific mixture of cement, sand, and water. In this standard, mortar is used to: (i) bond concrete blocks together, and (ii) plaster concrete walls and the underside of concrete slabs. Lime is highly recommended to improve the waterproofing capability and durability of mortar plaster used on external walls. Mortar must be used within one (1) hour of adding water.

### 5.1.8 Mixing cementitious materials

5.1.8.1. Concrete, grout and mortar should be mixed: (i) in a concrete mixer, or (ii) on a hard, smooth and relatively impermeable (non-absorptive) surface (eg. on concrete blinding bed). Grout must be used within one and one quarter (1.25) hours after adding water. The mixes are provided in Tables 1 for concreted and grouted elements, and Table 2 for mortar.

**Table 1 – Mixtures for concreted and grouted elements**

Elements	28-Day Compressive Cube Strength	Cement	Sand	Aggregate	Water	Slump
Footings	21 MPa (3,000 psi)	1 cu-ft x 5 gal)	2 cu-ft 3 x 5 gal)	4 cu-ft (6 x 5 gal)	5 gal	50 to 100 mm (2" to 4").
Beams Suspended slabs Columns	25 MPa (3,600 psi)	1 cu-ft (1.5 x 5 gal)	1.5 cu-ft 2.25 x 5 gal)	3 cu-ft (4.5 x 5 gal)	5 gal	50 to 100 mm (2" to 4").
Walls (grout for block's cores)	15.8 MPa (2,300 psi)	1 cu-ft (1.5 x 5 gal)	3 cu-ft (4.5 x 5 gal)	6 cu-ft (9 x 5 gal)	5 gal	115 to 230 mm (4 ½" to 9")
Note: One (1) bag of cement = 94 lb bag = 1 cu-ft = 1.5 x 5-gallon buckets.						

**Table 2 – Mixtures for mortar**

Element	28-Day Compressive Cube Strength	Cement	Lime (optional, but highly recommended for plaster)	Sifted Sand	Water
Mortar for repairs and below grade masonry work	16.8 MPa (2,400 psi)	1 cu-ft (1.5 x 5 gal)	½ cu-ft (0.75 x 5-gal)	3 cu-ft (4.5 x 5-gal)	50 to 100 mm (2" to 4").
Mortar for block joints and plastering walls above grade	11.2 MPa (1,600 psi)	1 cu-ft (1.5 x 5 gal)	½ cu-ft (0.75 x 5-gal)	4 cu-ft (4.5 x 5-gal)	50 to 100 mm (2" to 4").

5.1.8.2 The five (5) gallons of water is provided as a guide, since other factors like the dampness of the aggregate, may affect the amount of water required. The slump measure should be recorded and used to determine whether less or more than five (5) gallons of water is required.

5.1.8.3 The compressive strength of concrete is normally measured at 28 days. It is sampled at the site in either 150 mm (6") cubes or 100 mm (4") diameter, 200 mm (8") long cylinders, and crushed. The cylinder strength is approximately 80% of the cube strength (BS EN 1992-1-1:2004, Table 3.1) as shown in Table 3.

**Table 3 – Cylinder and cube compressive strength**

28-day Compressive Strength class	Minimum characteristic cylinder strength (MPa)	Minimum characteristic cube strength (MPa)
C12/15	12	15
C16/20	16	20
C20/25	20	25
C25/30	25	30

Source: BS EN 206:2013+A1:2016, Table 12

### 5.1.9 Concrete curing agent

Concrete curing agents may be spray-on curing compounds specified for tropical weather. Alternative curing methods are to cover the concrete with sand and keep it continuously wet for at least three (3) days, or cover the concrete with a plastic (polythene) sheet for at least 3 days.

### 5.1.10 Formwork release agent

Formwork release agent should effectively strip the formwork from the hardened concrete. Vegetable, mineral and engine oil are effective formwork release agents.

### 5.1.11 Reinforcement (rebar)

**5.1.11.1** Steel reinforcement (rebar) may be ribbed (deformed) high tension (high yield) steel rods (bars), or smooth mild steel rods (bars). The rebar should be reasonably free from rust, and tied together using mild steel tying wire.

**5.1.11.2** Rebar normally used in the Caribbean is manufactured to the American standard ASTM A615, and the British standards BS 4449 and 4482. The common American ASTM A615 rebar grades are Grade 60 for high tension 420 MPa (60,000 psi), and Grade 40 for mild steel 280 MPa (40,000 psi).

**5.1.11.3** The common British BS 4449 rebar grade is B500B for high tension 500 MPa (72,500 psi). The common British BS 4482 rebar grade for mild steel is 250 MPa (36,260 psi). Table 4 describes the diameters of each grade.

**Table 4 – Rebar diameters of each grade**

ASTM A615		BS 4449 and 4482*	
Bar Designation. [No.] Metric (imperial)	Nominal Diameter: Metric (imperial)	Bar Diameter. Metric (imperial)	Nominal Diameter: Metric (imperial)
-	-	6 mm (1/4")*	6.0 mm (0.236")*
-	-	8 mm (5/16")*	8.0 mm (0.315")*
[3] 10 mm (3/8")	9.5 mm (0.345")	10 mm (3/8")*	10.0 mm (0.345")*
[4] 13 mm (4/8")	12.7 mm (0.5")	12 mm (4/8")*	12.0 mm (0.5")*
[5] 16 mm (5/8")	15.9 mm (0.625")	16 mm (5/8")	16.0 mm (0.625")
[6] 19 mm (6/8")	19.1 mm (0.75")	20 mm (6/8")	20.0 mm (0.75")
[8] 25 mm (8/8")	25.4 mm (1")	25 mm (1")	25.0 mm (0.984")

Source: ASTM A615-15, Table 1. BS 4449:2005, Table 7. BS 4482:1985, Table 1.

**5.1.11.4** In this standard, high tension rebar diameters are prefixed with "H". For example, a 12 mm (1/2") diameter high tension rod is referenced H12. Mild steel diameters are prefixed with "R". For example, an 8 mm (5/16") diameter mild steel rod is referenced R8.

### 5.1.12 Rebar bend diameters

**5.1.12.1** Rebars should be bent around minimum bending diameters. For ASTM A615 high tension (Grade 60) rebars, the minimum bending diameter of the round former (mandrel), for rebar diameters 10 mm (3/8") to 25 mm (1") is six (6) times the diameter of the rebar (ACI 318-14, Table 25.3.1). For mild steel links (stirrups) it is four (4) times the diameter of the rebar (ACI 318-14, Table 25.3.1).

**5.1.12.2** For BS 4449 high tension 500 MPa and BS 4482 mild steel 250 MPa, the minimum diameter of the bending mandrel (round former), for rebar diameters less than or equal to 16 mm (5/16") is four (4) times the rebar diameter. For rebar diameters greater than 16 mm (5/16"), the minimum diameter of the bending mandrel (round former) is seven (7) times the rebar diameter (BS 8666-2020, Table 2. BS EN 1992-1-1:2004, Table 8.1N). Table 5 shows the minimum rebar diameters.

**Table 5 – Minimum bend diameters when type or rebar is known**

ASTM A615		BS 4449 and 4482*	
Bar Designation. [No.] Metric (imperial)	Minimum inside bend diameter Metric (imperial)	Bar Diameter. Metric (imperial)	Minimum inside bend diameter Metric (imperial)
-	-	6 mm (1/4")*	24 mm (0.94")*
-	-	8 mm (5/16")*	32 mm (1.26")*
[3] 10 mm (3/8")	57 mm (2.24")	10 mm (3/8")*	40 mm (1.57")*
[4] 13 mm (1/2")	76 mm (3.0")	12 mm (4/8")*	48 mm (1.90")*
[5] 16 mm (5/8")	95 mm (3.75")	16 mm (5/8")	64 mm (2.52")
[6] 19 mm (3/4")	115 mm (4.5")	20 mm (6/8")	140 mm (5.51")
[8] 25 mm (1")	152 mm (6.0")	25 mm (1")	175 mm (6.90")

**5.1.12.3** If the type of rebar is unknown, then the conservative minimum bend diameters shown in Table 6 should be used.

**Table 6 – Minimum bend diameters when type of rebar is unknown**

ASTM A615	BS 4449 and 4482*	Minimum inside bend diameter Metric (imperial)
Bar Designation. [No.] Metric (imperial)	Bar Diameter. Metric (imperial)	
-	6 mm (1/4")*	25 mm (1")
-	8 mm (5/16")*	32 mm (1.25")
[3] 10 mm (3/8")	10 mm (3/8")*	60 mm (2.36")
[4] 13 mm (1/2")	12 mm (4/8")*	76 mm (3")
[5] 16 mm (5/8")	16 mm (5/8")	95 mm (3.75")
[6] 19 mm (3/4")	20 mm (6/8")	115 mm (4.5")
[8] 25 mm (1")	25 mm (1")	175 mm (6.90")

### 5.1.13 Rebar lap lengths

To effectively transfer the tension load from one bar to another, the minimum lap length is fifty (50) times the rebar diameter.

### 5.1.14 Anchor bolts in concrete

Anchor bolts in concrete should be high-strength Grade 8.8. Washers in contact with timber should be 40 mm (1.5") diameter, 3 mm (1/8") thick galvanised steel.

### 5.1.15 Reinforced concrete

Reinforced concrete requires: (i) an accurate concrete mixture to obtain a minimum compressive strength and durability, (ii) safe reinforcement bend diameters and lap lengths to allow load transfer, (iii) spacers installed on all sides of the formwork, to obtain sufficient protective concrete cover to the reinforcement, (iv) compaction with a concrete vibrator, to obtain a dense concrete, and (v) curing to attain the intended (design) strength.

### 5.1.16 Concrete cover

**5.1.16.1** Concrete cover is used to protect the steel reinforcement from: (i) corrosion from exposure to the natural environment, and (ii) deformation from exposure to fire.

**5.1.16.2** The minimum cover requirements are determined from the most conservative American (ACI 314-14, Table 20.6.1.3.1) and British (BS EN 1991-1-1 and BS EN 1991-1-2) requirements, and are provided in Table 7.

**Table 7 – Concrete cover to rebars to give a minimum fire protection of 1.5 hours.**

Element	Concrete cover Metric, (Imperial)
Foundations – in contact with the ground	75 (3")
Slabs, walls, beams and columns exposed to weather	40 mm (1.5")
Slabs not exposed to weather	25 mm (1")
Walls not exposed to weather	25 mm (1")
Beam not exposed to weather	40 mm (1.5")
Column not exposed to weather	40 mm (1.5")

### 5.1.17 Concrete blinding

Concrete blinding may be used if the compacted fill on which the rebar is to be supported is uneven. A thin mass concrete blinding layer should provide a flat surface to accommodate the placement of reinforcement. A concrete blinding mixture that gives a 28-day compressive strength of approximately 7 MPa (1,000 psi) is 1 (cement) : 4 (sand) : 8 (aggregate).

### 5.1.18 Concrete formwork

**5.1.18.1** Formwork is used to form concrete footings, beams, slabs, and columns. Formwork may be comprised of timber that is made stable by bracing to prevent movement, and having close-fitting joints to reduce leakage of fine aggregate, cement or water. Figure 1 shows formwork for strip footings showing an example of bracing and close-fitting joints.

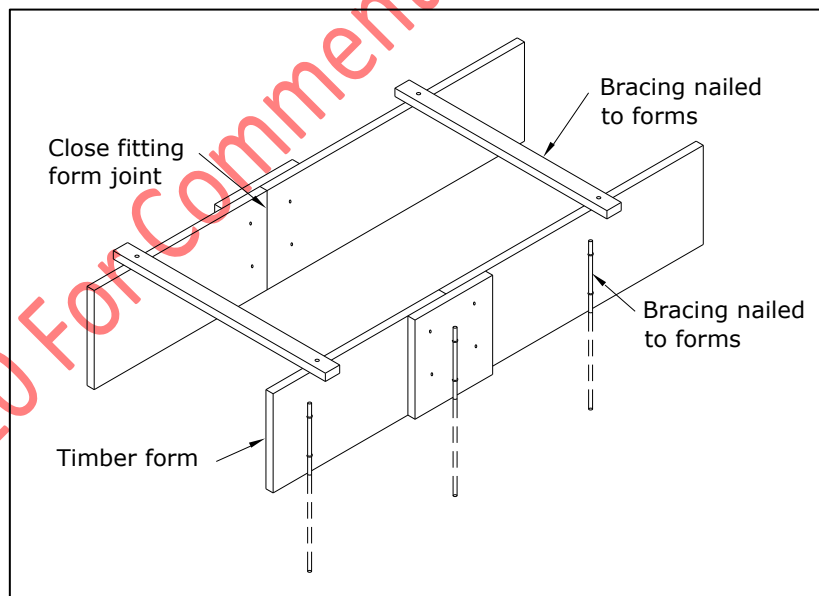

**Figure 1 – Formwork for strip footings.**

**5.1.18.2** It is important to check internal dimension for accuracy.

### 5.1.19 Concrete spacer blocks

Concrete spacer blocks or plastic or metal chairs are used to provide the specified concrete cover to the steel reinforcement, to protect the rebars from corrosion and fire. They should be connected to the rebar closest to the formwork as shown in Figure 2. For footings, they are also to be used to raise

the rebar off of the ground surface. The concrete used for the spacer blocks should be of similar strength of the concrete being formed.

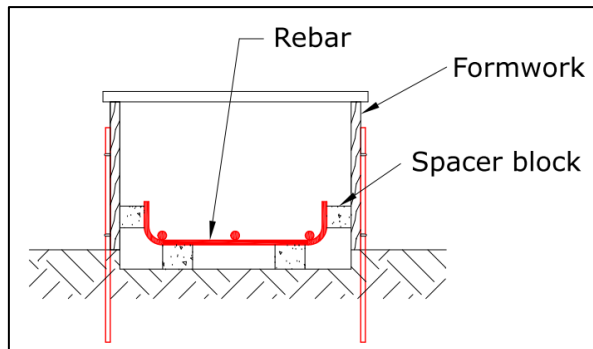

Figure 2 – Spacer block arrangement for strip footings.

### 5.1.20 Concrete and clay blocks

5.1.20.1 Concrete blocks should comply with the requirements of ASTM C90. Clay blocks should comply with the requirements of ASTM C652. The dimensional requirements are provided in Figure 3 and Table 8.

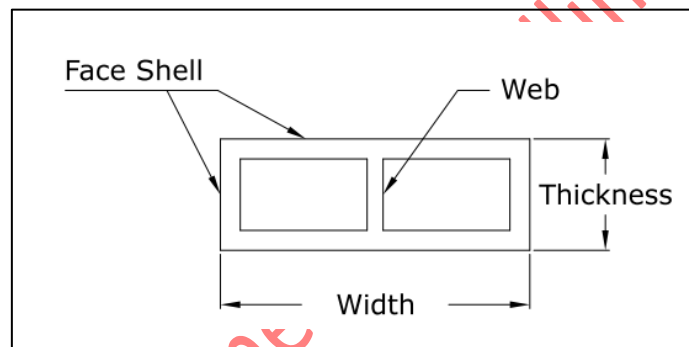

Figure 3 – Plan of concrete block.

Table 8 – Dimensions of concrete block

Nominal block size (Thickness x Width)	Concrete blocks		Clay blocks	
	Face shell thickness Metric (Imperial)	Web thickness Metric (Imperial)	Face shell thickness Metric (Imperial)	Web thickness Metric (Imperial)
150 mm x 400 mm (6" x 16")	25 mm (1")	19 mm (3/4")	25 mm (1")	25 mm (1")
200 mm x 400 mm (8" x 16")	32 mm (1.25")	19 mm (3/4")	32 mm (1.25")	25 mm (1")

5.1.20.2 The concrete blocks should have two hollow cores, and provide a minimum 28-day compressive strength of 7 MPa (1,000 psi) over the gross cross sectional plan area. *[In Trinidad & Tobago, the minimum compressive strength of one concrete block should be 12.4 MPa (1,800 psi), and the average of three (3) blocks should be a minimum of 13.8 MPa (2,000 psi).]*

5.1.20.3 The clay blocks should have two hollow cores, and provide a minimum 28-day compressive strength of 15.2 MPa (2,200 psi) over the gross cross sectional plan area.

5.1.20.4 During the construction of the supporting footings and slabs, cement should be washed off of the aggregate in areas where walls are to be built, to improve the bond.



**5.1.20.5** Blocks walls below ground level should be 200 mm (8") thick. Block walls above ground level should be a minimum of 150 mm (6") thick for single storey houses, and 200 mm (8") thick for two-storey houses.

**5.1.20.6** All cores on external walls below ground level should be filled solid with grout. Above ground, those cores with rebars, and those damaged by chasing, should be filled solid with grout. The grout should be poured in maximum lifts of three rows (courses) of blocks (or 600 mm (24")), leaving a 25 mm (1") key to resist lateral loads.

#### **5.1.21 Concrete and clay block rebars**

**5.1.21.1** Rebars should be placed at all wall junctions and ends. Exterior wall rebars should be high tension H12 (1/2") at 600 mm (24") centres. Interior wall rebars should be H12 (1/2") at 800 mm (32") centres).

**5.1.21.2** At block wall junctions, one H12 (1/2" diameter) rebar should be placed in the intersecting core, and in all cores bounding that intersecting core. Horizontal reinforcement must be placed in every other row (spaced 400 mm (16")). R6 (1/4" diameter mild steel) horizontal ties must be used to tie the vertical rebars at junctions. The ties should be spaced 400 mm (16") apart vertically.

#### **5.1.22 Fill**

Fill should be well graded granular fill, well compacted in placed in layers not exceeding 200 mm (8") thick before compaction.

#### **5.1.23 Utility pipes (plumbing, electrical, and communications)**

**5.1.24.1** Cold water supply pipes should be minimum Schedule 40 PVC pipes. While optional, it is highly recommended that plumbing pipes to be permanently exposed to sunlight should be Schedule 80 PVC.

**5.1.24.2** To join PVC pipes: (i) the contact surfaces of the pipe and the connector to be joined should be cleaned with pipe cleaner and then have pipe cement applied, (ii) the pipe should be inserted into the connector fully, and then turned one quarter of the circumference, (iii) the pipe should be held in the connector for at least 15 seconds to prevent it from moving out.

**5.1.24.3** Plumbing pipes should be pressure tested for leaks: (i) before pipes are covered by concrete, (ii) before pipes are embedded in walls, and (iii) before floors and walls are finished. Other utility pipes should be checked for blockages at these times. Pipes should be pressure tested to 1.5 times the operating pressure, and that pressure held for 24 hours.

**5.1.24.4** Concrete block walls should not be cut diagonally or horizontally to install pipes. Only vertical chases are permitted (preferably using an electric saw with a masonry blade to avoid excessive damage), and the blocks should be repaired by filling with grout.

**5.1.24.5** All pipe-lines should be capped, once the pipes in the line are laid and connected. The cap should then be removed to connect the line to junction boxes or fixtures.

#### **5.1.24 Timber frames**

Timber should be sound, straight, and well-seasoned, with a moisture content between 15% and 19%. Soft woods (e.g. Pine) should be pressure treated against insect attack.

#### **5.1.25 Timber walls on concrete**

Anchor bolts, 12 mm (1/2") in diameter, should be installed at 800mm (32") centres to connect the wall to the concrete beam or slab. A damp proof membrane should be placed between the timber and the concrete to reduce the risk of wet-rot.



### **5.1.26 Nails**

Nails should be minimum 8d (8 penny, 63 mm (2.5") long, 3.4 mm (1/8") diameter) galvanised common wire nails. They should mainly be used to hold timber in place until a permanent connection is made with wood-grip screws.

### **5.1.27 Roof metal cladding**

Corrugated metal roof cladding should be minimum 0.6 mm (24 gauge) thick profiled metal sheeting, connected to the timber frame with No.12 wood grip screws for external use. The metal cladding should be protected from corrosion, by complying with the following standards, or their equivalent, ASTM A653, or ASTM A924.

### **5.1.28 Damp proofing membrane (DMP)**

Damp proofing membrane (DPM) should be minimum 500 gauge (125 microns) polythene vapour membrane barrier with 350 mm (14") taped laps. Utility pipes protruding through the DPM should also be taped.

## **5.2 Pre-construction planning**

### **5.2.1 Planning Approval**

Before construction starts, Development Planning approval must be obtained. Obtaining Planning approval is the responsibility of the Employer (normally the home-owner). A property that has planning approval should have, among other things: (i) accurate and identifiable boundary markers, (ii) dimensions to set-out the house, and (iii) provision for sewage disposal. Variations to the contract that change the internal or external geometry of the building, should be resubmitted for Development Planning approval.

### **5.2.2 Contract**

Before construction starts, the Contractor (builder) should have a written contract with the Employer (home owner). The contract should include: (i) Contractor's obligations, (ii) Employer's obligations, (iii) procedures for making changes to the contract, (iv) procedures for resolving disputes, and (v) insurance requirements.

#### **5.2.2.1 Contractor's obligations**

The Contractor's obligations should include the agreement to build the house that was approved by the planning authorities, using specified construction standards, for a specified amount of money, and within a specified period of time.

#### **5.2.2.2 Employer's obligations**

The Employer's obligations should include the agreement to pay a specified sum of money, within a specified period of time after receiving the Contractor's invoice, and according to a specified payment schedule.

#### **5.2.2.3 Variations**

Whenever an Employer requests a change to their building project (or Contract), the Contractor should provide the Employer with: (i) the additional cost (or saving) of the change, and (ii) the extension or reduction in time to complete the change, for the Employer's written approval.

#### **5.2.2.4 Resolving disputes**

Contracts should have a named independent adjudicator, who shall be agreed to by both parties, who may be invited by either side to decide an unresolved dispute within two weeks. The adjudicator's decision shall be final and binding, unless one party notifies the other in writing, within two weeks of

the decision, of their intent to appeal the decision through arbitration or litigation. In that case, the adjudicators decision is binding until practical completion, or should the contract be terminated.

### **5.2.3 Insurance**

The Contractor should indemnify the Employer, and insure against personal injury or death of any person, and damage to property, in the course of completing the contracted work. The insured amount should a minimum of five (5) years of earnings if no national legislation exists. If the Contractor fails to secure this insurance, the Employer shall obtain the insurance and deduct the cost from amounts due to the Contractor.

### **5.2.4 Drawing Review**

The Contractor shall examine all drawings to check whether they contain sufficient information to both price (cost) and build the house. The Contractor should request any missing information from the Employer. The Contractor should state any assumptions used in the price quotation, if the missing information is not provided. The Contractor should state the assumed depth to the footings.

## **5.3 Site preparation**

### **5.3.1 Site Inspection**

The contractor shall inspect the site to determine: (i) the location of: boundary markers, resident neighbours, access roads, trees on the site, and nearby drainage or sewerage wells, (ii) the direction of prevailing winds, (iii) the slope of the site, (iv) the condition of nearby drains and any flooding concerns, and (v) the locations for storing: excavated soil, materials and equipment delivered to the site, and waste materials. The contractor should obtain professional advice as required.

### **5.3.2 Site Investigation**

**5.3.2.1** The contractor should investigate the site by: (i) protecting boundary markers, (ii) clearing the site of overgrown vegetation, (iii) setting out the external walls, (iii) excavating to hard formation at the corners and approximate centre of the building to determine the likely depth of footings, and (iv) excavating any contractual sewerage or drainage disposal wells to determine likely subsoil conditions.

**5.3.2.2** Professional engineering advice should be obtained if any: voids (caves), cracks (joints or fissures), large boulders, large trees, compressible material (peat, other organic material, refuse), fill, ground water, or weak soil layers below the planned footings are observed.

**5.3.2.3** The Employer should be notified in writing about any new issue that may: (i) increase construction costs, (ii) delay construction activities, and/or (iii) extend the duration of the construction contract.

### **5.3.3 Work plan**

Based on the results of the site inspection and investigation, the Contractor should prepare a workplan (project schedule) of construction activities, including an ordered list of activities, and when they are planned to be done given the available Contractor resources. Additional resources may be required to complete the project within the specified time.

### **5.3.4 Setting Out**

A dimensioned grid, aligned with the middle of the walls, should be drawn on the plan. Any missing dimensions to prevent the accurate setting out of the grid on the site, should be requested from the Employer.

### **5.3.5 Material storage**

Cement bags, timber, and rebars should be stored in a dry location and elevated at least 100 mm (4") off the ground. Sand and stone should be covered to prevent them from being blown or washed

away, and to prevent excessive wetting which may alter the water content of the concrete and/or mortar mixture.

### 5.3.6 Batter Boards

Batter boards should be aligned to the grids. Batter boards, where the horizontal member is greater than 300 mm (12") from the ground surface, should have a 25 mm x 100 mm (1" x 4") diagonal bracing member installed, as shown in Figure 4. Three nails should be installed at the top of the horizontal members, representing the middle and edges of the proposed walls.

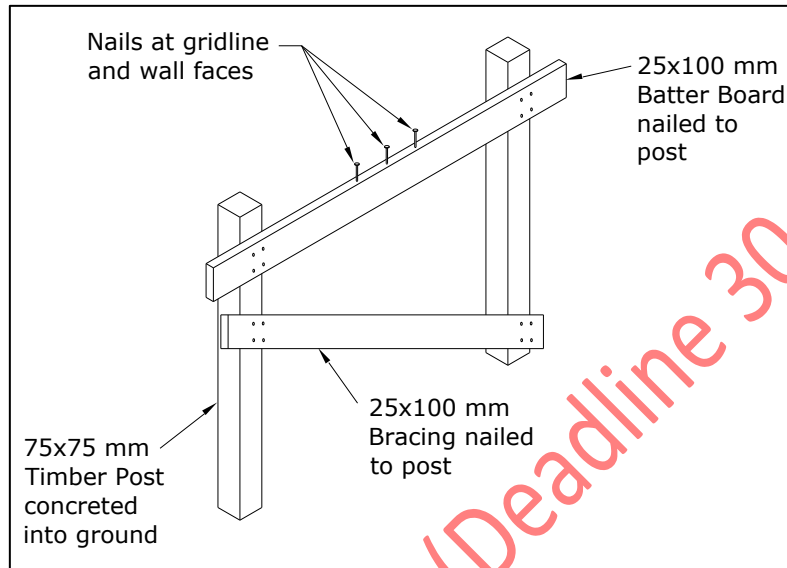

Figure 4 – Batter boards.

### 5.3.7 Risk Assessments

The risk assessments for the site preparation activities are provided in Table 9.

Table 9 – Risk assessment

Activities	Risks	Risk Mitigation Measures
Walking around the site.	Stepping on nails.	Wear hard shoes.
Walking around the site.	Being accused of trespassing.	Wear a safety vest.
Constructing batter boards	Harm to hands with hand tools (hammer and saws).	Wear safety gloves. Wear safety glasses.
Excavating well	Falling in open well.	Securely cover the open well.

## 5.4 Foundations

Foundation activities include: (i) assessing the bearing capacity of the layer of soil on which footings are to be founded, (ii) excavating to that bearing layer, (iii) applying termite treatment to that layer, and (iv) constructing the footing.

### 5.4.1 Bearing capacity

Where available, national soil maps with bearing capacities, and national authorities with jurisdiction to determine soil bearing capacities, should be consulted to determine the bearing capacity of the soil. If there is uncertainty, then Engineering advice should be obtained. The maximum allowable safe bearing capacity for various soils is provided in Table 10.

**Table 10 – Maximum allowable safe bearing capacity of soils**

Soil	Maximum Allowable Safe Bearing Capacity when Dry [Wet]	
	(kN/m <sup>2</sup> )	(Tons/sq-ft)
1. Thick layers (beds) of hard unweathered limestones and sandstones.	4,000 [4,000]	40 [40]
2. Strong shales, mudstones and siltstones.	2,000 [2,000]	20 [20]
3. Thin layers (beds) of limestones and sandstones.	1,000 [1,000]	10 [10]
4. Compact well-graded fill.	400 [200]	4 [2]
5. Loose well-graded sands	200 [100]	2 [1]
6. Compact uniform sands.	200 [100]	2 [1]
7. Loose uniform sands.	100 [50]	1 [0.5]
8. Stiff clays and sandy clays.	200 [100]	2 [1]
9. Firm clays and sandy clays.	100 [50]	1 [0.5]
10. Soft clays and silts.	50 [0]	0.5 [0]

Source: OECS Building Code, 2016. Table 13-1.

## 5.4.2 Excavations

**5.4.2.1** Excavate a minimum of 900mm (3 ft) to a good foundation layer (dense sand, stiff clay), or to rock, to reduce or prevent settlement. If the depth of excavation is greater than 1.2m (4 ft), then: (i) support the sides by installing vertical planks and horizontal struts, or (ii) cut back the sides to a slope of 1.5 horizontal : 1 vertical.

**5.4.2.2** Inspect the bottom of the excavation. If the foundation is rock, then provide a key by excavating at least 50 mm (2") into the rock. If the bottom of the excavation is loose, then the foundation bottom can be compacted by ramming. If pockets of unsuitable material (eg, clay) are found, then they should be removed. Deep areas and over excavated areas may be backfilled with compacted granular material or with mass concrete (1 (cement) : 3 (sand) : 6 (stone)). If clay is found or if there is uncertainty, then Engineering advice should be obtained.

## 5.4.3 Termite treatment

After excavating to a good bearing layer, the ground under the footings and floors should be treated for termites. A reputable pesticide company that offers a minimum 5-year warrantee should be used.

## 5.4.4 Footings

**5.4.4.1** Footings should be designed to support the building by the underlying material (including soil: type, moisture content, and slope), and to prevent the building from moving during natural hazards.

**5.4.4.2** Masonry-walled houses should be founded on reinforced concrete: (i) strip footings, (ii) pad footings, or (iii) slab-on-ground foundations. Timber-walled houses should be founded on one of the same type of footings for masonry-walled houses, or on timber posts.

### 5.4.4.3 Strip footings

**5.4.4.3.1** On relatively flat ground, with slope less than 1 (Vertical) : 8 (Horizontal), reinforced concrete strip footings may be a more economical option.

**5.4.4.3.2** Strip footings should have the size and reinforcement specified in Table 11, that corresponds to the soil type and bearing capacity.

**Table 11 – Strip footing sizes and reinforcement**

Structural Element [Bearing Capacity]	Minimum Size (width x depth)	Minimum Concrete 28-day compressive cube strength	Minimum Reinforcement
Strip footing on stiff clays. [100 kN/m <sup>2</sup> (1 Ton/sq-ft)]	760 mm x 300 mm (30"x12")	21 MPa (3,000 psi)	2 x H12 (1/2") rebars longitudinally + H12 mm rebars spaced at 300 mm (12") centres transversely.
Strip footing on compacted granular soil. [200 kN/m <sup>2</sup> (2 Tons/sq-ft)]	600 mm x 275 mm (24"x11")	21 MPa (3,000 psi)	2 x H12 (1/2") rebars longitudinally + H12 mm rebars spaced at 300 mm (12") centres transversely.
Strip footing on rock. [450 kN/m <sup>2</sup> (4.5 Tons/sq-ft)]	400 mm x 275 mm (16"x11")	21 MPa (3,000 psi)	2 x H12 (1/2") rebars longitudinally + H12 mm rebars spaced at 300 mm (12") centres transversely.
Ring beam at floor level.	200 mm x 200 mm (8"x8")	25 MPa (3,600 psi)	4xH12mm (1/2") bars with T6mm links at 150mm (6") spacing.

**5.4.4.3.3** The construction method includes the following: (i) excavate to a good bearing layer, (ii) apply termite treatment to the soil under the footings, (iii) place mass concrete (1:4:8) blinding, (iv) erect formwork to fit the strip footings, (v) place reinforcement, including wall starter bars, in the formwork, (vi) install spacers to the bottom and sides, (vii) remove any debris from within forms, (viii) apply a release agent to the formwork surface to be in contact with concrete, and (ix) pour, compact, level, trowel finish, and cure the concrete.

**5.4.4.3.4** Once the concrete has been cured, the foundation walls should be built as shown in Figure 5. The method includes the following: (i) install foundation wall rebars, (ii) lay foundation blocks, (iii) grout foundation blocks every three (3) courses, leaving a key.

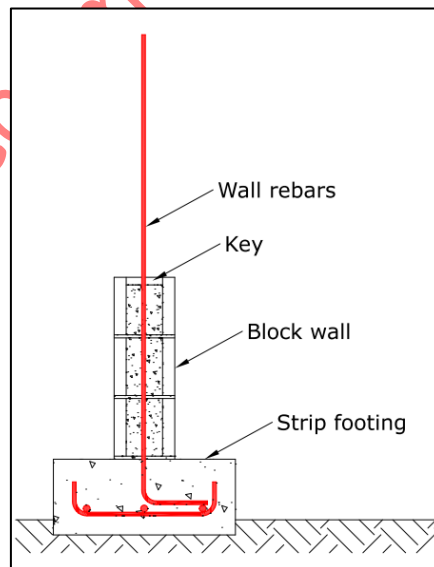

**Figure 5 – Strip footing.**

**5.4.4.4 Pad footings**

**5.4.4.4.1** If the land is sloping steeply, or undulating severely, then reinforced concrete (RC) pad footings supporting RC columns and beams may be an economical option.

**5.4.4.4.2** Pad footings are to have the size, strength, and reinforcement specified in Table 12, that corresponds to the soil type and bearing capacity. They are to be connected with 200 mm x 300 mm (8" x 12") RC tie beams (with 2 H12 longitudinal rebars and R6 @ 200 links) to prevent them from moving during seismic loads.

**Table 12 – Pad footing sizes and reinforcement**

<b>Pad Footing [Bearing Capacity]</b>	<b>Minimum Size (length x width x depth )</b>	<b>Minimum Concrete 28-day compressive cube strength</b>	<b>Minimum Reinforcement</b>
Pad footing on stiff clays. [100 kN/m <sup>2</sup> (1 Ton/sq-ft)]	1,200 mm x 1,200 mm x 300 mm (48"x48"x12")	21 MPa (3,000 psi)	H12 at 150 mm (6") spacing each way top and bottom.
Pad footing on compacted granular soil. [200 kN/m <sup>2</sup> (2 Tons/sq-ft)]	950 mm x 950 mm x 300 mm (39"x39"x12")	21 MPa (3,000 psi)	H12 at 150 mm (6") spacing each way top and bottom.
Pad footing on rock. [450 kN/m <sup>2</sup> (4.5 Tons/sq-ft)]	650 mm x 650 mm x 300 mm (27"x27"x12")	21 MPa (3,000 psi)	H12 at 150 mm (6") spacing each way top and bottom.

**5.4.4.4.3** The construction method includes the following: (i) excavate to a good bearing layer, (ii) apply termite treatment to the soil under the footings, (iii) place mass concrete (1:4:8), (iv) erect formwork to fit the pad, (v) place reinforcement including column starter bars in the formwork, (vi) install tie-beam reinforcement, (vii) install spacers to the bottom and sides, (viii) remove any debris from within the forms, (ix) apply a release agent to the formwork surface to be in contact with concrete, and (x) pour, compact, level, trowel finish, and cure the concrete.

**5.4.4.4.4** Once the concrete has cured, the columns and beams should be constructed. The method includes the following: (i) lap column rebars at midspan, and install the column links (stirrups), (ii) install the formwork on three sides, (iii) install the spacers, (iv) install formwork release agent, (v) install the final formwork side, (vi) pour, compact, level, trowel finish, and cure the concrete, (vii) install beam formwork, (viii) install beam rebars, (ix) install starter bars for concrete block walls, or anchor bolts for the timber frame, (x) install spacers, (xi) install formwork release agent, and (xii) pour, compact, level, trowel finish, and cure the concrete.

**5.4.4.4.5** Columns are to have the size, strength, and reinforcement specified in Table 13, and arranged in Figure 6, that corresponds to the column height.

**Table 13 – Concrete column sizes and reinforcement**

<b>Column Height</b>	<b>Minimum Size</b>	<b>Minimum Concrete 28-day compressive cube strength</b>	<b>Minimum Reinforcement</b>
Less than 3.0m (10 ft) high.	200 mm x 200 mm (8"x8")	25 MPa (3,600 psi)	Mai rebars: 4xH12 Links: T6 at 150 mm spacing.
3.0m (10 ft) to 3.65m (12 ft) high.	250 mm x 250 mm (10"x10")	25 MPa (3,600 psi)	Mai rebars: 4xH16 Links: T8 at 200 mm spacing.
3.65m (12 ft) to 4.3m (14 ft) high.	300 mm x 300 mm (12"x12")	25 MPa (3,600 psi)	Mai rebars: 4xH20 Links: T8 at 250 mm spacing.

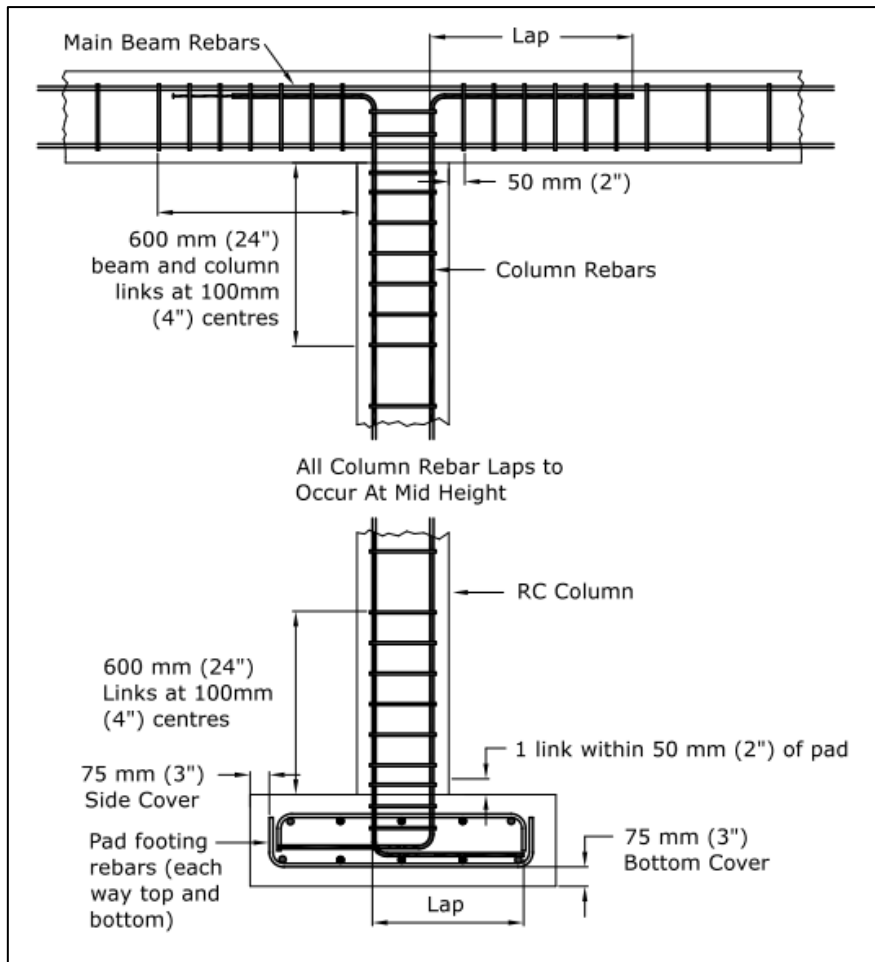

Figure 6 – Pad footing and column.

#### 5.4.4.5 Slab-on-Ground footings

5.4.4.5.1 When good bearing soil is deep, then a slab-on-ground foundation, which integrates the footings into the ground floor slab, can be supported on well compacted granular fill material. A slab-on-ground foundation can also be used on relatively flat land, where hard rock is close enough to the surface to allow the footings to be cast on the rock, or on fill on the rock.

5.4.4.5.2 Slab-on-ground footings (with masonry walls) should have the minimum geometry as shown in Figure 7. The minimum 28-day concrete compressive cube strength should be 21 MPa (3,000 psi). The rebar layout for masonry walls is shown in Figure 8. The rebar layout for timber framed walls is shown in Figure 8.

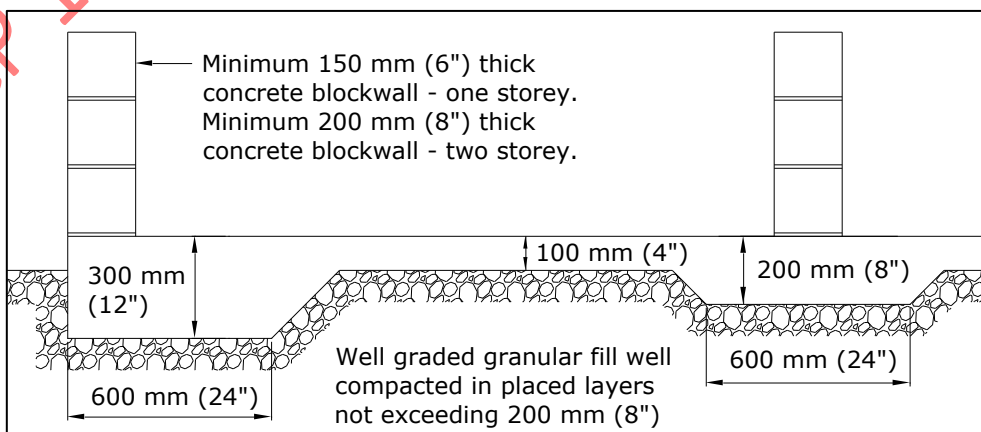
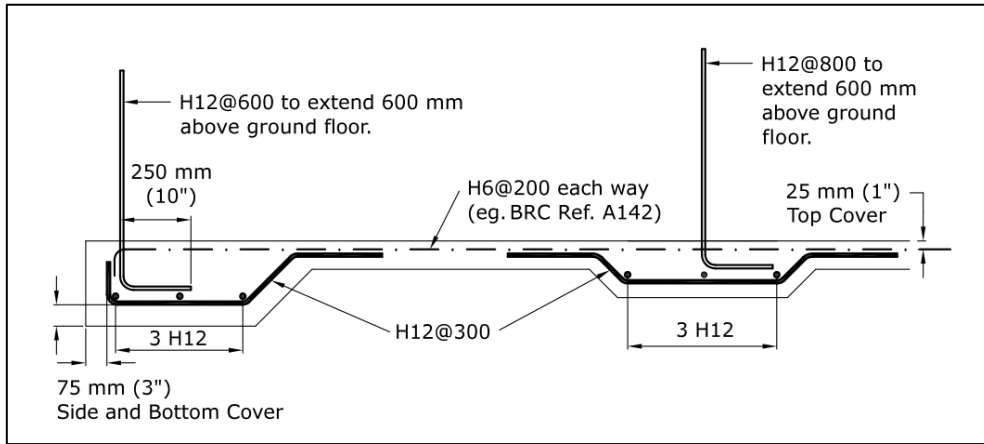
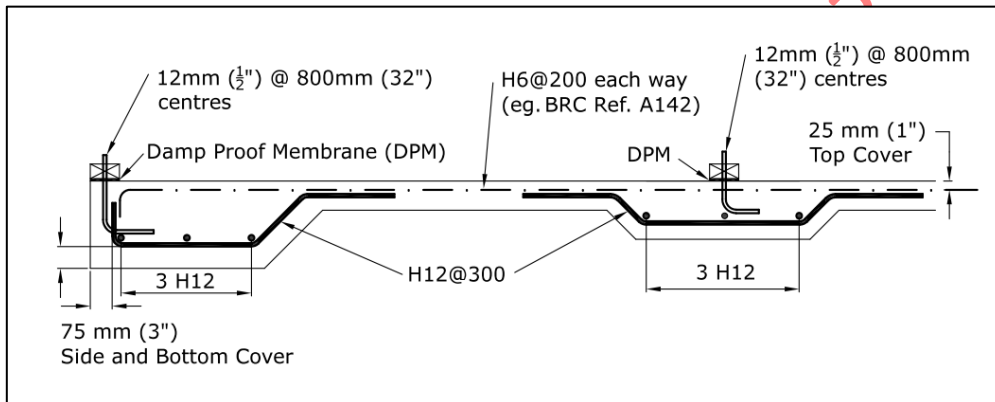

Figure 7 – Layout of slab-on-ground footing.





**Figure 8 – Rebar layout of slab-on-ground footing (masonry walls).**



**Figure 9 – Rebar layout of slab-on-ground footing (timber framed walls).**

Note: BRC Ref. A142 is a square mesh or 6 mm (1/4") rebar at 200 mm (8") square pattern.

**5.4.4.5.3** The construction method includes the following: (i) excavate to a good bearing layer, (ii) apply termite treatment to the soil under the slab and footings, (iii) install fill, (iv) cut trenches for slab thickenings, (v) install plumbing waste, electrical, communications, and security pipes in the fill, (vi) install termite treatment, (vii) erect formwork, (viii) place damp proof membrane, (ix) place reinforcement, (x) place wall starter rebars for masonry walls or anchor bolts for timber walls, (xi) install spacers to the bottom and sides, (xii) remove any debris from within forms, (xiii) apply a release agent to the formwork surface to be in contact with concrete, and (xiv) pour, compact, level, trowel finish, and cure the concrete.

#### **5.4.4.6 Timber posts**

**5.4.4.6.1** A relatively inexpensive foundation for a timber building, is to drive 100 mm x 100 mm (4"x4") minimum Greenheart or termite treated braced timber posts, at least 1.2 m (4 ft) into the ground, as shown in Figure 10. The posts may also be placed in an excavated (augured) hole and concrete around. The embedded posts should be waterproofed, for example, with bituminous paint.



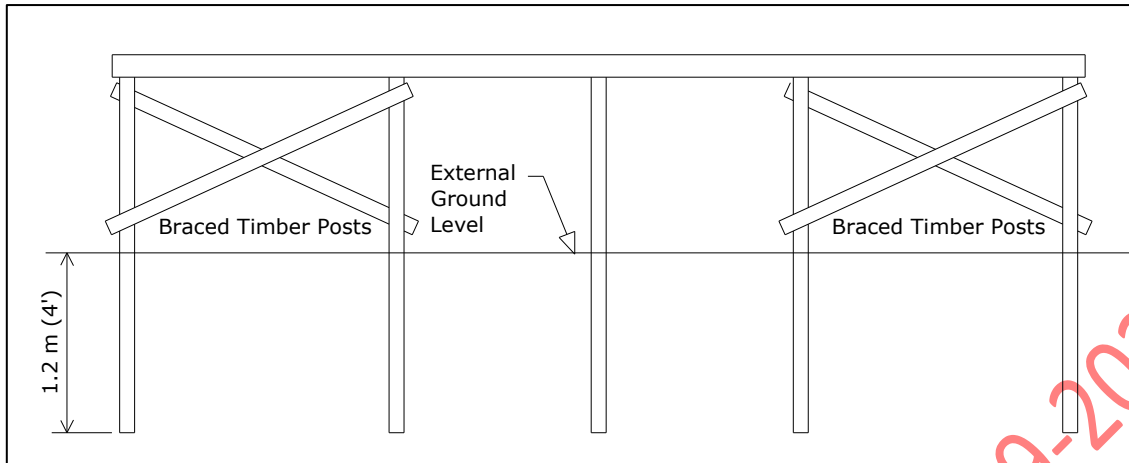

**Figure 10 – Braced timber post foundation.**

**5.4.4.6.2** For concreted posts, the construction method includes the following: (1) excavate a hole, (ii) apply termite treatment to the sides and top, (iii) place the timber post in the hole, (iv) pour, compact, level, trowel finish, and cure the concrete, and (v) brace the posts.

## 5.5 Floors

The floor is used to support the floor loads and to transmit them to the foundations. There are 3 types described in this standard: (i) reinforced concrete slab on fill, (ii) suspended reinforced concrete slab, and (iii) suspended timber floor.

### 5.5.1 Reinforced concrete slab on fill

**5.5.1.1** There are two types of concrete slabs on fill: (i) the slab-on-ground foundation covered in Section 5.4.4.5, and (ii) the slab on strip footings as shown in Figure 11. The strip footings were covered in Section 5.4.4.3.

**5.5.1.2** Once the footings have been built, the construction method includes the following: (i) install fill, (ii) install utility pipes, (iii) install termite treatment pesticide, (iv) install damp proof membrane (including blinding where necessary), (v) install beam and slab rebars, (vi) install starter bars for concrete block walls, or anchor bolts for timber frame, (vii) install formwork, (viii) install spacers, (ix) install water supply pipes, (x) install formwork release agent, (xi) pour, compact, level, trowel finish, and cure the concrete, and (xii) plaster the external walls.

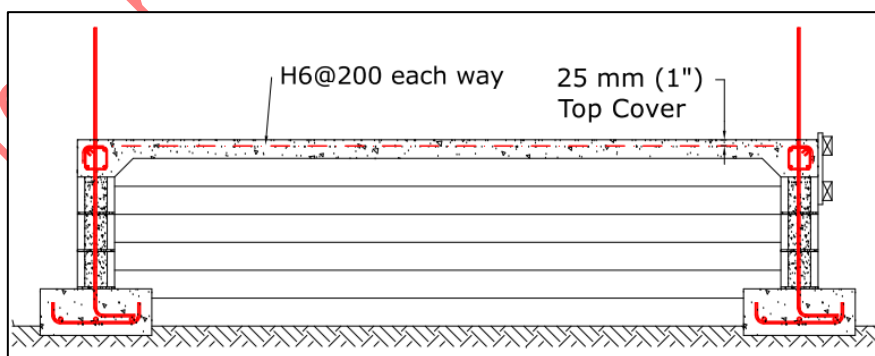

**Figure 11 – Slab on strip footings.**

### 5.5.2 Suspended reinforced concrete floor slab

Suspended reinforced concrete slabs are supported by reinforced concrete beams on: (i) strip footings, or (ii) columns.

Suspended reinforced concrete slabs (shown in Figure 12) should have the strength size and reinforcement as specified in Table 14, that corresponds to the span.

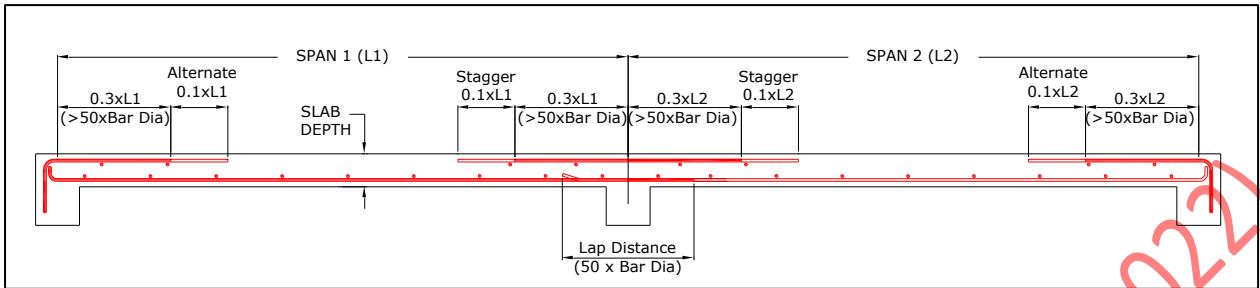

Figure 12 – Slab rebar layout.

Table 14 – Slab thickness and reinforcement.

Slab Thickness mm (inch)	Span between supporting walls.					
	1.8 m (6 ft)	2.4 m (8 ft)	3 m (10 ft)	3.6 m (12 ft)	4.3 m (14 ft)	4.8 m (16 ft)
100 (4")	H12@300					
125 (5")		H12@300	H12@300			
150 (6")			H12@300	H12@300		
175 (7")				H12@300	H12@250	
200 (8")					H12@250	H12@200
225 (9")						H12@200

Notes:

1. Minimum secondary rebars to be H10 (3/8") at 300 mm (12") centres.
2. Use the thicker slab for higher than normal loads (eg. library, storage, home-gym), or stone floor tiles (eg porcelain) but Engineering advice should be obtained for verification.
3. Concrete 28-day compressive cube strength to be 25 MPa (3,600 psi).

### 5.5.3 Cantilevered reinforced concrete slab

Cantilevered reinforced concrete slabs (shown in Figure 13) should have the strength size and reinforcement as specified in Table 15, that corresponds to the span.

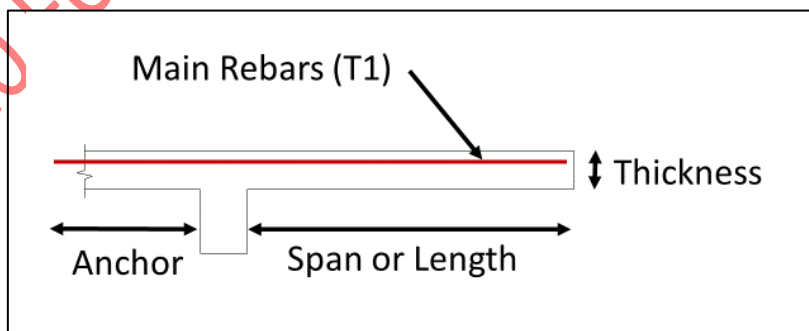

Figure 13 – Cantilever slab.

**Table 15 – Cantilever slab thickness and reinforcement.**

Cantilever Slab Thickness mm (inch)	Cantilever span or length.			
	1.2 m (4 ft)	1.8 m (6 ft)	2.4 m (8 ft)	3.0 m (10 ft)
125 (5")	H12@300			
150 (6")	H12@300	H12@300		
150 (6")		H12@300		
200 (8")			H12@200	
200 (8")			H12@200	H12@150
250 (8")				H12@150

Notes:

1. Minimum secondary rebars to be H10 (3/8") at 300 mm (12") centres.
2. Use the thicker slab for higher than normal loads (eg. storage, home-gym), or stone floor tiles (eg porcelain) but Engineering advice should be obtained for verification.
3. Concrete 28-day compressive cube strength to be 25 MPa (3,600 psi).
4. Minimum anchorage to be the greater of: (i) 1.5 x cantilever span, (ii) 0.3 x supported span, or (iii) 50 x bar diameter

#### 5.5.4 Suspended Timber Floor

**5.5.4.1** Suspended timber floor joists are to have the strength and size, specified in Table 16 for 400 mm (16") spacing, and Table 17 for 600 mm (24") spacing.

**Table 16 – Timber joist sizes at 400 mm (16") spacing**

Span Range	Joist Size at 400mm centres	
	Pine SS	Purpleheart
1.5 m to 1.8 m (5 ft to 6 ft)	50 mm x150 mm (2"x6")	50 mm x 100 mm (2"x4")
1.8 m to 2.4 m (6 ft to 8 ft)	50 mm x 200 mm, 75 mm x 150 mm (2"x8", 3"x6")	50 mm x150 mm (2"x6")
2.4 m to 3.3 m (8 ft to 10 ft)	50x250, 75x200 (2"x10", 3"x8")	50 mm x 200 mm, 75 mm x 150 mm (2"x8", 3"x6")
3.3 m to 3.6 m (10 ft to 12 ft)	75 mm x 200 mm (3"x8")	50 mm x 200 mm (2"x8")
3.6 m to 4.3 m (12 ft to 14 ft)	75 mm x 250 mm (3"x10")	50 mm x 250 mm, 75 mm x 200 mm (2"x10", 3"x8")
4.3 m to 4.8 m (14 ft to 16 ft)	75 mm x 300 mm (3"x12")	75 mm x 250 mm (3"x10")

**Table 17 – Timber joist sizes at 600 mm (24") spacing**

Span Range	Joist Size at 600mm centres	
	Pine SS	Purpleheart
1.5 m to 1.8 m (5 ft to 6 ft)	50 mm x 150 mm (2"x6")	50 mm x 100 mm (2"x4")
1.8 m to 2.4 m (6 ft to 8 ft)	50 mm x 200 mm, 75 mm x 150 mm (2"x8", 3"x6")	50 mm x 150 mm (2"x6")
2.4 m to 3.3 m (8 ft to 10 ft)	75 mm x 200 mm (3"x8")	50 mm x 150 mm (2"x6")
3.3 m to 3.6 m (10 ft to 12 ft)	75 mm x 250 mm (3"x10")	50 mm x 200 mm, 75 mm x 150 mm (2"x8", 3"x6")
3.6 m to 4.3 m (12 ft to 14 ft)	75 mm x 300 mm (3"x12")	50 mm x 200 mm, 75 mm x 200 mm (2"x8", 3"x8")
4.3 m to 4.8 m (14 ft to 16 ft)	100 mm x 300 mm (4"x12")	50 mm x 250 mm, 75 mm x 200 mm (2"x10", 3"x8")

**5.5.4.2** When placing timber on concrete, a damp proof membrane must be placed between the timber and the concrete member.

**5.5.4.3** If the size of timber joists are not available, then the joist's span may be reduced by installing a timber bearer beam on concrete or masonry piers (plinths), as shown in Figure 14.

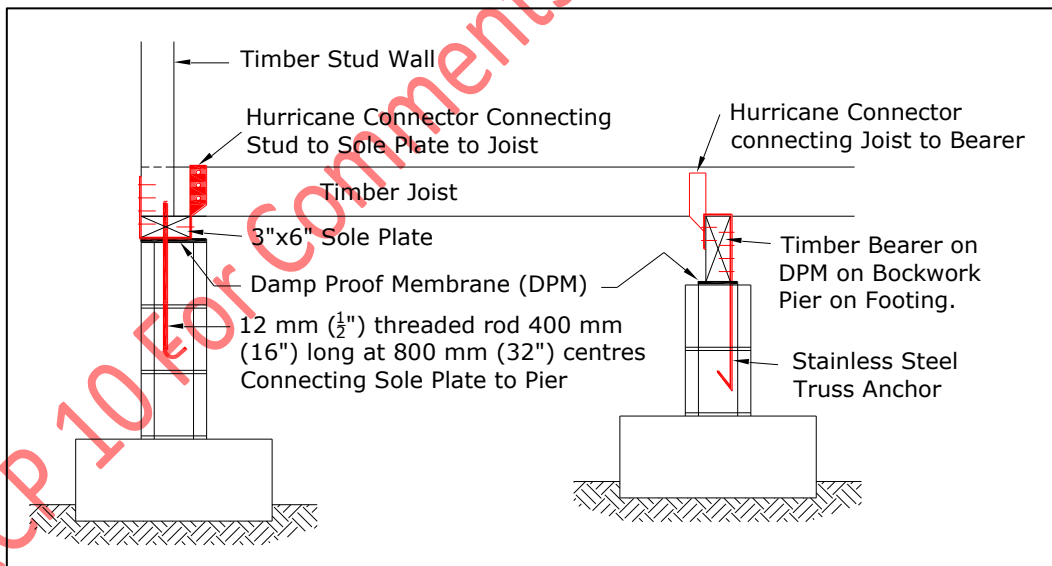

**Figure 14 – Timber bearer on masonry plinth.**

**5.5.4.4** The construction method includes the following: (i) construct the supporting beam, (ii) install a damp proof membrane, (iii) bold a 75 mm x 150 mm (3"x6") timber sole plate/sill to the concrete beam, (iv) connect timber joists to the sole plate, (v) install 25 mm (1") thick tongue and groove floor planks to the joists, and (vi) install joist bracing (as shown in Figure 15) at 2.1 m (7 ft) intervals if the joist depth is 200 mm (8") or more.

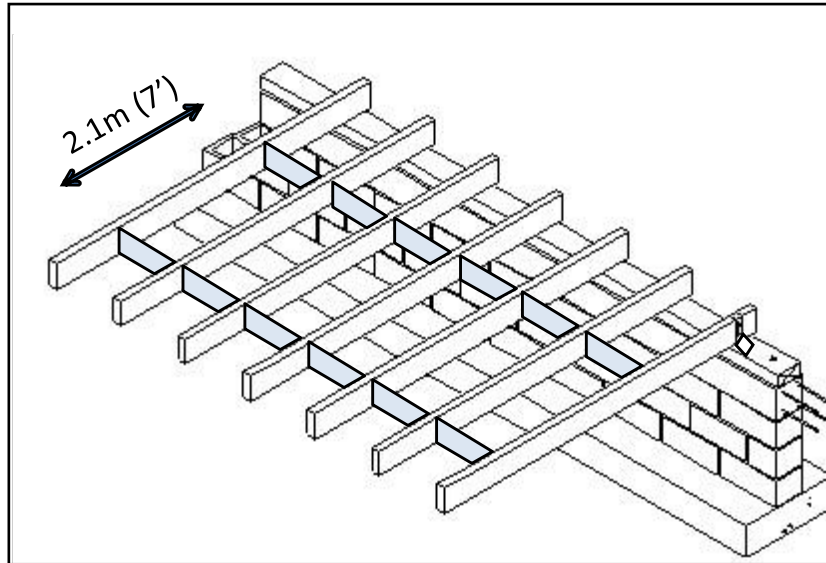

Figure 15 – Joist bracing.

### 5.5.5. Stairs

Reinforced concrete stairs are to have the geometry as shown in Figure 16 and Table 18, and the strength, and reinforcement as specified in Table 19, that corresponds to the span. The maximum rise (riser) is 210 mm (8.25") (OECS 2016, Table 5-5), but 150 mm (6") is comfortable and practical. The minimum run (tread) 227 mm (9"), but 300 mm (12") is comfortable and practical. The minimum landing is 915 mm (36") (OECS 2016, Section 505.10).

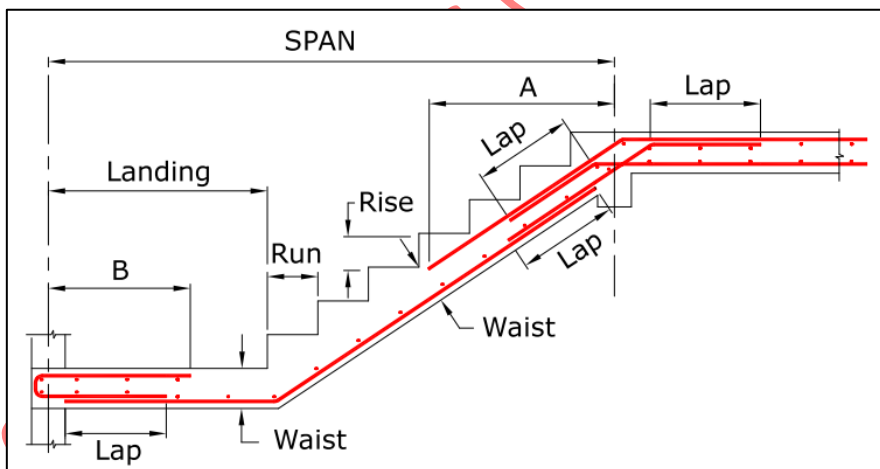

Figure 16 – Stair layout and rebar.

Table 18 – Stair geometry

Span	A (m)	B (m)	Waist (mm)
2.4 m (8')	0.7 m (28")	0.6 m (2')	125 mm (5")
3 m (10')	0.9 m (3')	0.6 m (2')	150 mm (6")
3.6 m (12')	1.1 m (3'-6")	0.6 m (2')	175 mm (7")
4.2 m (14')	1.3 m (4'-3")	0.65 m (26")	200 mm (8")

**Table 19 – Slab thickness and reinforcement.**

Slab Thickness mm (inch)	Span between supporting walls.					
	1.8 m (6 ft)	2.4 m (8 ft)	3 m (10 ft)	3.6 m (12 ft)	4.3 m (14 ft)	4.8 m (16 ft)
100 (4")	H12@300					
125 (5")		H12@300	H12@300			
150 (6")			H12@300	H12@300		
175 (7")				H12@300	H12@250	
200 (8")					H12@250	H12@200
225 (9")						H12@200

Notes:  
 1. Minimum secondary rebars to be H0 (3/8") at 300 mm (12") centres.  
 2. Use the thicker slab for higher than normal loads or stone floor tiles (eg porcelain) but Engineering advice should be obtained for verification.  
 3. Concrete 28-day compressive cube strength to be 25 MPa (3,600 psi).

## 5.6 Walls and beams

Two types of walls are specified in this standard: (i) concrete block masonry, and (ii) timber framed.

### 5.6.1 Concrete block walls.

**5.6.1.1** Masonry walls can fail in both horizontal and vertical planes. Therefore, these walls must be reinforced both horizontally and vertically as shown in Figure 17.

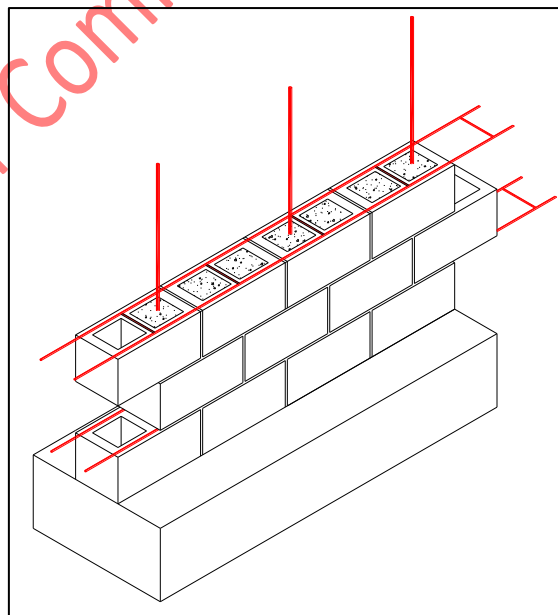

**Figure 17 – Horizontal and vertical masonry reinforcement.**

**5.6.1.2** Each wall elevation must have shear resistance, consisting of either one 3.0 m (10 ft) long shear walls, or two 1.8 m (6 ft) long shear panels. These shear walls must be constructed from foundation to roof, with no openings (windows or doors).

**5.6.1.3** Vertical Reinforcement for external walls is to be H12@600 (1/2" bars at 24" centres). Vertical reinforcement for internal walls is to be H12@800 (1/2" bars at 32" centres). Horizontal reinforcement is to be 3.6 mm diameter galvanised wire at each face, at 400 mm (16") centres.

**5.6.1.4** The construction method includes the following: (i) construct the floor with wall starter bars extending 600 mm (2 ft) above the floor level, (ii) install wall vertical reinforcement, (iii), lay three block courses, including horizontal rebar and links every other course and raked joints, (iv) grout the courses with rebar every three courses, and include a key, (v) repeat items ii to iv until the roof beam level, (vi) install beam formwork, (vii) install beam rebars, (viii) install spacers, (ix) install hurricane truss anchors, (x) install spacers, (xi) pour, compact, level, trowel finish, and cure the concrete, and (xii) plaster the wall.

**5.6.2 Concrete Stiffeners**

**5.6.2.1** Reinforced concrete stiffeners are required every 7.6 m (25 ft) of unbraced wall. If the unbraced length is long, then multiple stiffeners must be installed at 6 m (20 ft) maximum spacing. Stiffeners should be at least 300mm (1 ft) wide, and toothed into the wall as shown in Figure 18. The thickness of the concrete stiffener is the wall thickness.

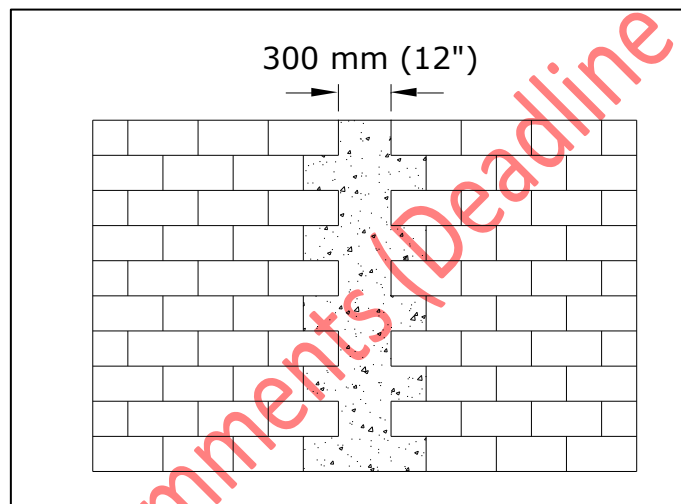
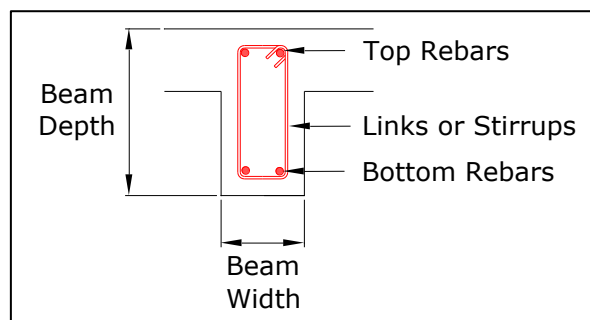

**Figure 18 – Concrete stiffener in masonry wall.**

**5.6.2.2** Minimum vertical rebars are to be 4 H12 (1/2") anchored to the foundation and perimeter beam. Minimum links are to be R6 (1/4") spaced at 300 mm (12") centres.

**5.6.3 Reinforced concrete wall support suspended beams**

The components of a reinforced concrete suspended beam are shown in Figures 19 and 20. Reinforced concrete suspended beams are to have the strength, size, and reinforcement as specified in Table 20, that corresponds to the span.



**Figure 19 – Reinforced concrete suspended beam.**

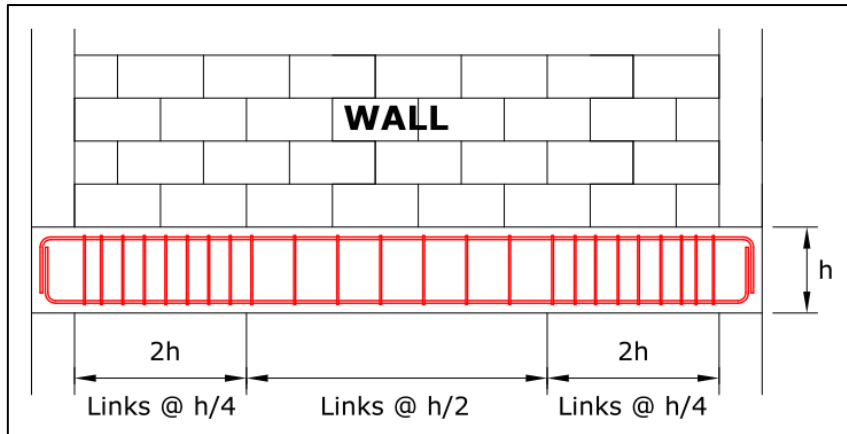

Figure 20 – Reinforced concrete suspended beam.

Table 20 – Beam sizes and rebars

Maximum Span (m)	Minimum Depth (mm)	Top Rebars	Bottom Rebars	Links @ Spacing (mm)
2.4 m (8')	325 mm (13")	2H12	2H16	H8@150 (6")
3.0 m (10')	350 mm (14")	2H12	2H16	H8@150 (6")
3.6 m (12')	375 mm (15")	2H16	2H20	H8@200 (8")
4.3 m (14')	400 mm (16")	2H20	2H25	H8@200 (8")

Notes:  
 1. Concrete 28-day compressive strength to be 25 MPa (3,600 psi).  
 2. Assumes beam supports concrete block wall and part of roof.

#### 5.6.4 Reinforced concrete lintel beams

Reinforced concrete lintel beams are to have the strength, size, and reinforcement as specified in Table 21, that corresponds to the span as shown in Figure 21.

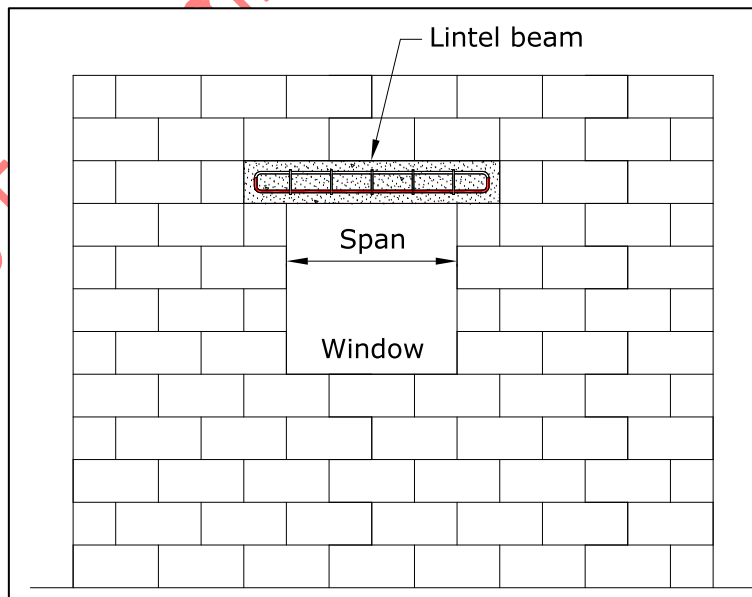

Figure 21 – Lintel beam.

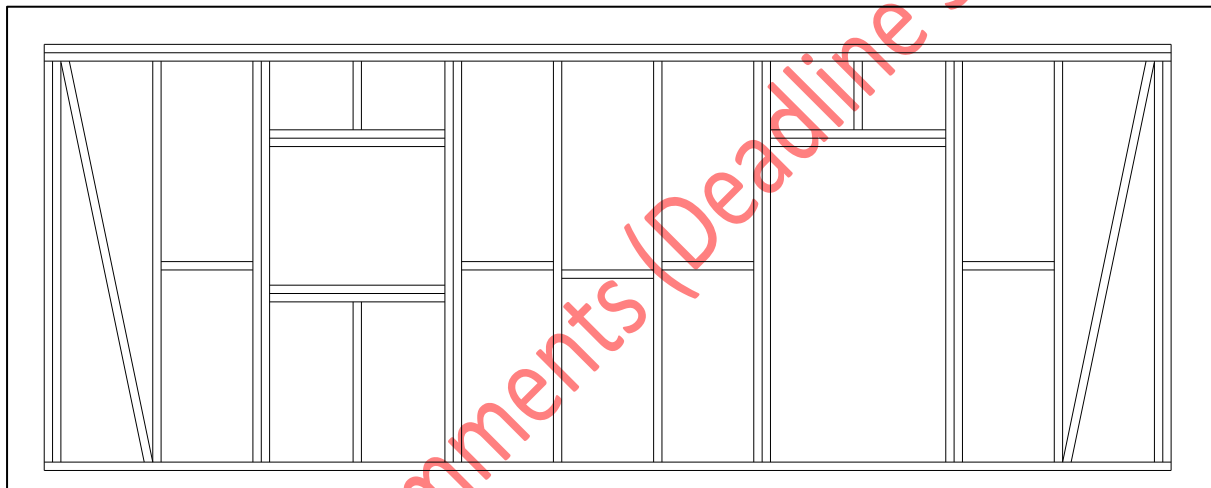

**Table 21 – Lintel beam sizes and rebars.**

Span of Lintel m (ft)	Beam size (width x depth)	Main Rebar Number x Size	Links Dia @ mm centres
Up to 1.0 m (0 to 3')	150x200 mm (6"x8")	4xH12	H8@150 mm
1.0 to 1.8 m (3' to 6')	(200x200 mm (8"x8"))	4xH12	H8@150 mm
1.8 to 2.4 m (6' to 8')	200x400 mm (8"x16")	2xH12 (top) 2xH16 (bottom)	H8@200 mm
Note: Concrete 28-day compressive cube strength to be 25 MPa (3,600 psi).			

**5.6.5 Timber walls.**

**5.6.5.1.** Timber walls are to be constructed of 2.4 m (8') high 50 mm x 100 mm (2"x4") timber studs. Pine studs should have a minimum spacing of 450 mm (18") on centre. Greenheart studs should have a minimum spacing of 600 mm (24") on centre. Studs should be doubled at the wall's ends, top, and around openings. A typical stud layout is shown in Figure 22.



**Figure 22 – Layout of wall timber frame.**

**5.6.5.2** All wall junctions are to be braced as shown in Figure 23.

DCRCP 10 For Comments (Deadline 30/09-2022)

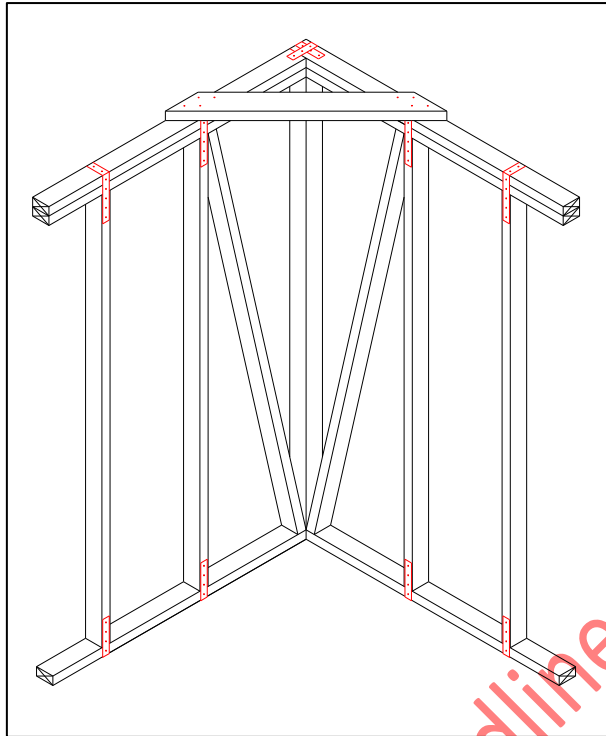

**Figure 23 –Timber frame bracing at wall junctions.**

**5.6.5.3** The construction method includes the following: (i) construct the sole plate or timber beam to support the studs, (ii) install the vertical studs, (iii) install additional studs at the at corners, and the sides of windows and doors, (iv) install the top plate, (v) install diagonal bracing and noggins, (vi) install utility pipes and junction boxes, (vii) install hurricane straps to support the rafters, and (viii) install wall cladding.

**5.6.5.4** Wall cladding for internal and external walls should be: (i) 20 mm (3/4") thick ship lap boards, or (ii) 10 mm (3/8") thick plywood sheets, or equivalent. Wall cladding should be painted with a waterproof paint.

## **5.7 Roof**

**5.7.1** This standard specifies timber roof frames supported by: (i) reinforced concrete beams on masonry walls, and (ii) timber framed walls.

**5.7.2** The roof consists of cladding, supported on 50 mm x 100 mm (2"x4") treated Pine purlins (battens) spaced at 600 mm (24"). The purlins are to be supported on 16 mm (5/8") thick plywood, supported on rafters, supported on walls. The purlins may be supported directly on the rafters as shown in Figure 24.

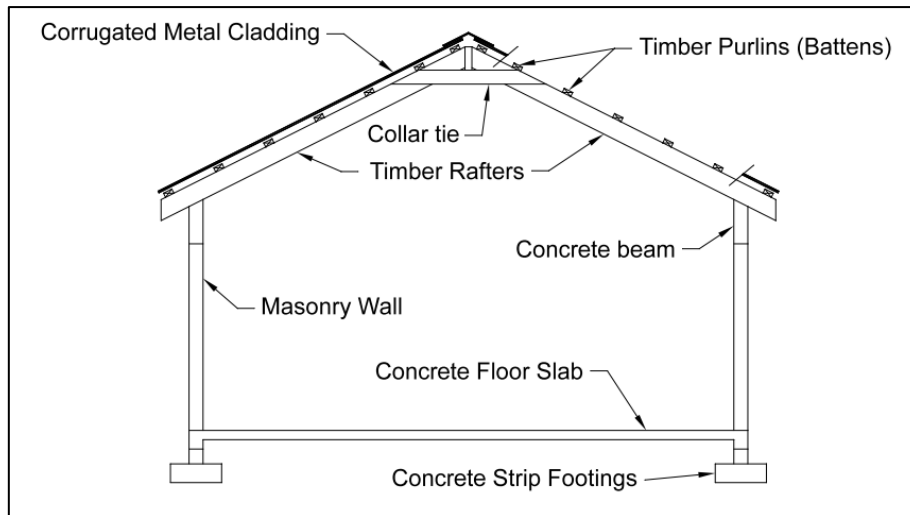

**Figure 24 – Section through house showing roof.**

**5.7.3** Main (common) timber rafters for hipped roofs are to have the strength size and spacing as specified in Tables 22 and 23 for Category 5 hurricanes, that corresponds to the rafter span. For comparison, common rafters for a Category 2 hurricane are shown. Hip and ridge members should be 50 mm (2") deeper than the connecting rafters.

**Table 22 – Rafter sizes at 400 mm (16") span.**

Span	Category 5 Hurricane		Category 2 Hurricane	
	Rafter Size at 400mm (16") centres		Rafter Size at 400mm (16") centres	
	Pine SS	Purpleheart	Pine SS	Purpleheart
1.5-1.8 m (5-6ft)	50x150 (2"x6")	50x100 (2"x4")	50x100 (2"x4")	50x100 (2"x4")
1.8-2.4m (6-8ft)	75x150 (3"x6")	50x150 (2"x6")	50x150 (2"x6")	50x100 (2"x4")
2.4-3.3 (8-10ft)	75x200 (3"x8")	75x150, 50x200 (3"x6", 2"x8")	50x150 (2"x6")	50x150 (2"x6")
3.3-3.6m (10-12')	75x200 (3"x8")	75x150, 50x200 (3"x6", 2"x8")	50x150 (2"x6")	50x150 (2"x6")
3.6-4.3m (12-14')	75x250 (3"x10")	50x200 (2"x8")	75x150 (3"x6")	50x150 (2"x6")
4.3-4.8m (14-16')	75x300 (3"x12")	75x200 (3"x8")	75x150 (3"x6")	50x150 (2"x6")

**Table 23 – Rafter sizes at 600 mm (24") span.**

Span	Category 5 Hurricane		Category 2 Hurricane (Trinidad)	
	Rafter Size at 600mm (24") centres		Rafter Size at 600mm (24") centres	
	Pine SS	Purpleheart	Pine SS	Purpleheart
1.5-1.8 m (5-6ft)	50x150 (2"x6")	50x100 (2"x4")	50x150 (2"x6")	50x100 (2"x4")
1.8-2.4m (6-8ft)	50x200 (2"x8")	50x150 (2"x6")	50x150 (2"x6")	50x150 (2"x6")
2.4-3.3 (8-10ft)	75x250 (3"x10")	50x200, 75x150 (2"x8", 3"x6")	50x200, 75x150 (2"x8", 3"x6")	50x150 (2"x6")
3.3-3.6m (10-12')	75x250 (3"x10")	75x200 (3"x8")	75x200 (3"x8")	50x150 (2"x6")
3.6-4.3m (12-14')	75x300 (3"x12")	75x200 (3"x8")	75x200 (3"x8")	75x150 (3"x6")
4.3-4.8m (14-16')	75x300 (3"x12")	75x250 (3"x10")	75x250mm (3"x10")	75x150 (3"x6")

#### 5.7.4 Roof on masonry walls.

For a roof on masonry walls, the construction method includes the following: (i) erect falsework to support the ridge members, (ii) install the ridge members, including any hips, (iii) install the rafters, (iv) install hurricane connectors, (v) install concrete to fill the space between rafters, (vi) install tongue and groove close-boards or plywood (for example T1-11), (vii) install purlins (battens), (viii) install insulation (optional), (ix) if metal cladding is to be used, install a damp proof membrane, rubberised paint, or rubberised tape on top of purlins, and (x) install cladding.

#### 5.7.5 Roof on timber framed walls.

For a roof on timber framed walls, the construction method includes the following: (i) erect falsework to support the ridge member, (ii) install the ridge members, including any hips, (iii) install the rafters, (iv) install hurricane connectors, (v) install tongue and groove close-boards or plywood (for example T1-11), (vi) install purlins (battens), (vii) install insulation (optional), (viii) if metal cladding is to be used, install a damp proof membrane, rubberised paint, or rubberised tape on top of purlins, and (ix) install cladding.

#### 5.7.6 Reducing the Span

Rafter sizes can be reduced by reducing the span by: (i) supporting the rafter on an internal wall, (ii) installing a 50 mm x 150 mm (2"x6") timber collar tie at a lower level (including making an A frame), and (iii) building a truss. Some reduced span concepts are shown in Figure 25.

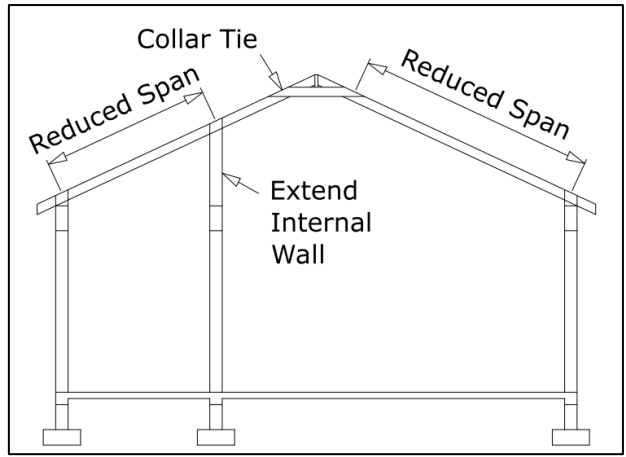

Figure 25 – Span reducing concepts.

**5.7.7 Roof Connections.**

Roof cladding connections are to be as shown in Figures 26 to 29. The hurricane connectors should be 1.0 mm thick (18 gauge) galvanised metal with a minimum tensile strength of 450 MPa.

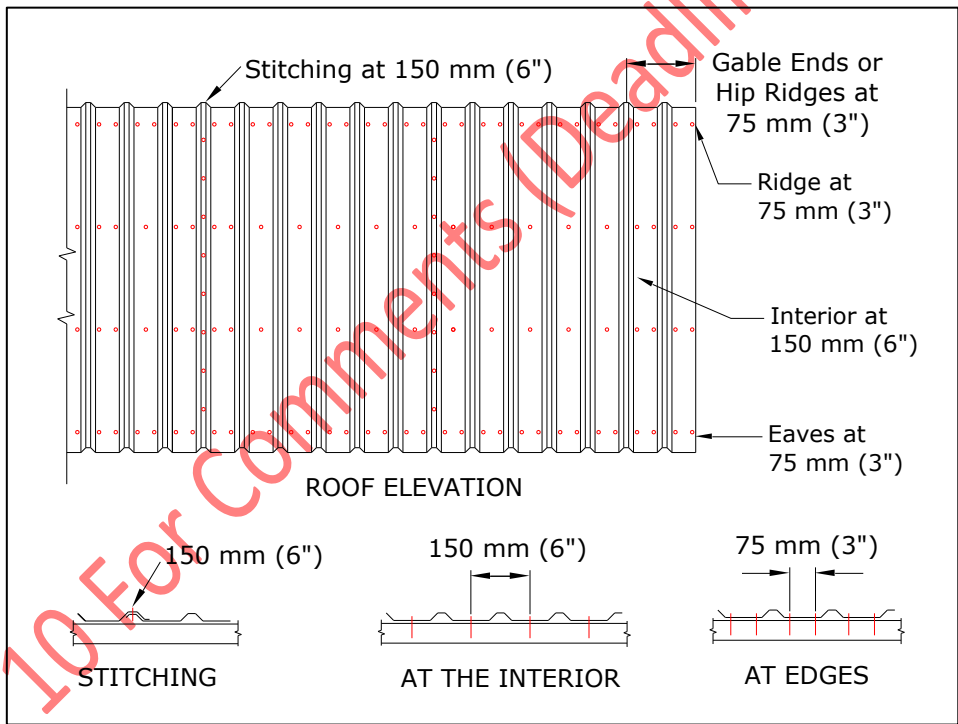

Figure 26 – Roof cladding connections.

DCRCP 10 For Comments (Deadline 30-09-2022)

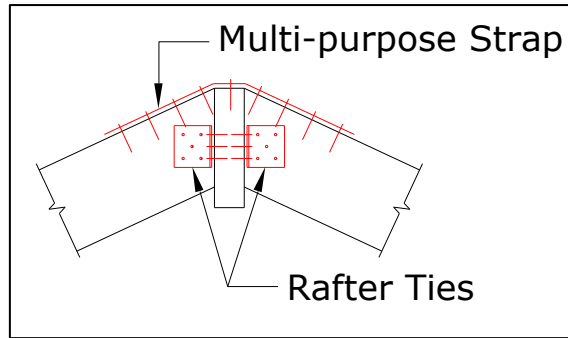

Figure 27 – Rafter connections at the ridge.

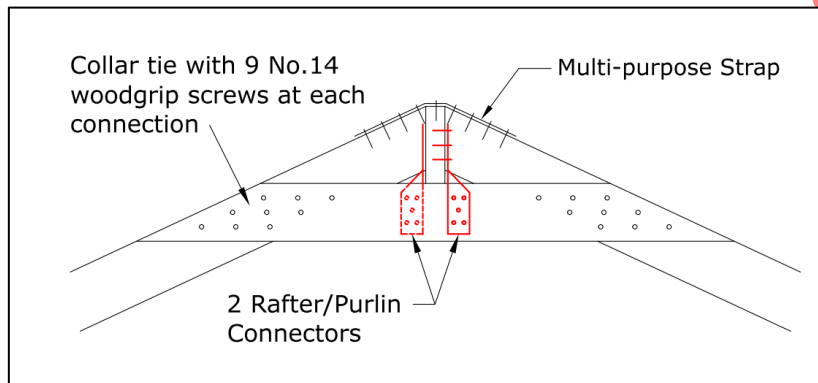

Figure 28 – Collar tie at ridge.

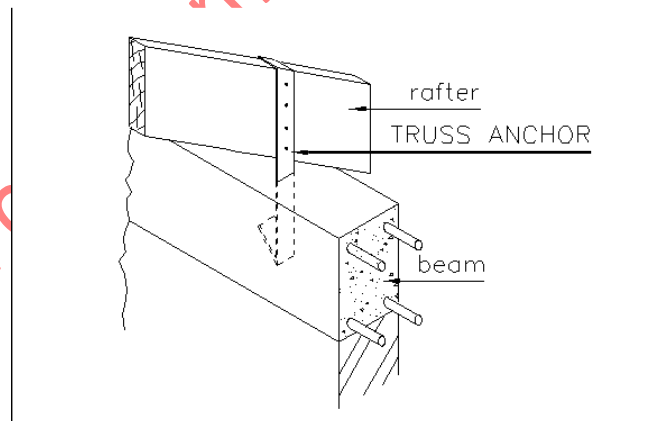

Figure 29 – Truss anchor.

## **Annex A**

*(Informative)*

### **A.1 Post-construction maintenance**

**A.1.1** There are four (4) principal construction phases, (i) design, (ii) construction, (iii) maintenance, and (iv) demolition. Neglecting the maintenance requirements can hasten the start of the demolition phase. Addressing the building's maintenance may prolong the design life of the building.

**A.1.2** Houses in the Caribbean may deteriorate rapidly if their materials are not protected from the environment. Examples of deterioration are: (i) corrosion of metal reinforcement, cladding and fixings, (ii) moisture damage to timber and paints, (iii) insect damage to timber, (iv) tree root damage to footings and walls, (v) air pollution damage to concrete, (vi) head and ultra-violet light damage to paint, pipes, plastic gutters, and soil chemistry damage to concrete footings.

**A.1.3** To reduce the maintenance requirements, low-maintenance materials and construction methods should be used. The following are recommended.

- a) Use compacted concrete and grout.
- b) Protect reinforcement with adequate concrete cover.
- c) Use strong blocks and mortar.
- d) Use suspended ground floor slabs or slabs supported on well compacted fill on rock.
- e) Use treated timber.
- f) Use stainless steel straps and fixings.
- g) Use stainless steel or bronze hinges.
- h) Use cleaned and cemented schedule 80 PVC pipes externally.
- i) Use paint with fungicide (eg. Trowel Plastic).
- j) Seal all open spaces (around pipes, around openings, between rafters.)
- k) Install roof gutters and discharge stormwater away from foundations.
- l) Seal joints and paint all exposed timbers.
- m) Apply waterproofing agent (Vandex, Penetron, Xypex, or equivalent) to basement walls, and install a drain.

### **A.2 Design for Elderly and Disabled People**

#### **A.2.1 Maintenance**

Elderly and disabled persons normally have a challenge in maintaining their properties. If good quality materials are used, and assembled properly, then the house will not attract high maintenance requirements.

#### **A.2.2 Building Access**

The walkway from the street to the house should be at least 1.5 m (5 ft) wide, with a slope of at least 1:20. Allowance should be made for a ramp width of 914 mm (32") and slope of 1:12. At the entrance, the length of the landing should be at least 2 m (80") as shown in Figure A.1.

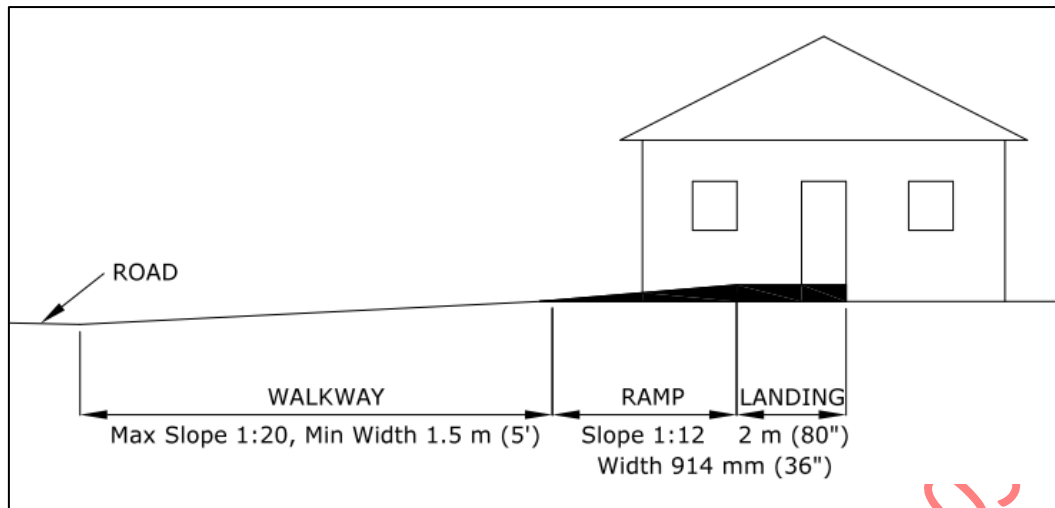

**Figure A.1 – Access for disabled.**

### **A.2.3 Doors and Corridors**

All external doors and bathroom doors should open outwards. All door openings should be 810 mm (32") wide. Door levers should be used, not door knobs. All corridors should be a minimum width of 1 m (40").

### **A.2.4 Kitchen, Laundry and Bathrooms**

A clearance of 1,370 mm (54") should be provided around all: cabinets, counter tops, ovens, washers, driers, tubs, and any other furniture or appliance.

### **A.2.5 Electrical Light Fixtures**

All electrical light bases are to accommodate screw type bulbs.

**END OF DOCUMENT**





## **CARICOM REGIONAL ORGANISATION FOR STANDARDS AND QUALITY**

The CARICOM Regional Organisation for Standards and Quality (CROSQ) was created as an Inter-Governmental Organisation by the signing of an agreement among fourteen Member States of the Caribbean Community (CARICOM). CROSQ is the regional centre for promoting efficiency and competitive production in goods and services, through the process of standardization and the verification of quality. It is the successor to the Caribbean Common Market Standards Council (CCMSC), and supports the CARICOM mandate in the expansion of intra-regional and extra-regional trade in goods and services.

CROSQ is mandated to represent the interest of the region in international and hemispheric standards work, to promote the harmonization of metrology systems and standards, and to increase the pace of development of regional standards for the sustainable production of goods and services in the CARICOM Single Market and Economy (CSME), and the enhancement of social and economic development.

### **CROSQ VISION:**

The premier CARICOM organisation for the development and promotion of an Internationally Recognised Regional Quality Infrastructure; and for international and regional harmonized CARICOM Metrology, Standards, Inspection, Testing and Quality Infrastructure

### **CROSQ MISSION:**

The promotion and development of standards and standards related activities to facilitate international competitiveness and the sustainable production of goods and services within the CARICOM Single Market and Economy (CSME) for the enhancement of social and economic development

DCRCP 10 For Comments (Deadline 30-09-2022)



© CROSQ 202x – All rights reserved

ISBN \_\_\_\_\_

ICS \_\_\_\_\_